



# COMTRAXX® MK800



**Alarm indicator and test combination**

**Software version: 4.1x**



**Bender GmbH & Co. KG**

P.O. Box 1161 • 35301 Gruenberg • Germany  
Londorfer Straße 65 • 35305 Gruenberg • Germany  
Tel.: +49 6401 807-0 • Fax: +49 6401 807-259  
E-mail: [info@bender.de](mailto:info@bender.de) • [www.bender.de](http://www.bender.de)

© Bender GmbH & Co. KG  
All rights reserved.  
Reprinting only with permission  
of the publisher.  
Subject to change!

# Table of Contents

<b>1. How to get the most out of this manual .....</b>	<b>7</b>
1.1 How to use this manual .....	7
1.2 Explanation of symbols and notes .....	8
<b>2. Safety instructions .....</b>	<b>9</b>
2.1 Intended use .....	9
2.2 Qualified personnel .....	10
2.3 General safety instructions .....	11
2.4 Delivery conditions, warranty and liability .....	11
<b>3. System description .....</b>	<b>13</b>
3.1 MEDICS® .....	13
3.2 Characteristics .....	14
3.3 Functionality .....	16
3.3.1 Display/operating elements .....	16
3.3.2 Programmable messages .....	16
3.3.3 History memory .....	17
3.4 Versions .....	17
3.4.1 MK800-12 .....	17
3.4.2 MK800-11 .....	17
3.4.3 Interfaces .....	17
3.4.3.1 Internal BMS bus .....	18
3.4.3.2 External BMS bus .....	18
3.4.3.3 USB interface .....	18
<b>4. Installation and connection .....</b>	<b>19</b>
4.1 Installation .....	19
4.1.1 Flush-mounting .....	19
4.1.2 Cavity wall mounting .....	20

4.1.3	Control panel mounting without enclosure .....	21
4.1.4	Control panel mounting with enclosure .....	22
4.1.5	Use bezel frame .....	23
4.1.6	Surface-mounting enclosure .....	24
4.2	Connection .....	26
4.2.1	Connection details .....	27
4.2.2	Wiring diagram .....	28
4.2.2.1	Connection assignment MK800-12 .....	30
4.2.2.2	Connection assignment MK800-11 .....	30
4.2.3	Examples for BMS bus connection and addressing .....	31
4.2.4	Address settings and their meaning .....	35
<b>5.</b>	<b>Commissioning and testing .....</b>	<b>37</b>
5.1	Tests before switching on .....	38
5.2	Tests after switching on .....	39
5.3	Make settings (parameterisation) .....	39
5.3.1	Settings on the MK800 .....	40
5.3.2	Settings using the TMK-SET software .....	41
5.3.3	Tests after parameter setting .....	42
5.4	Periodic verification and service .....	43
5.4.1	Periodic verification .....	43
5.4.2	Service and support .....	44
5.4.3	Maintenance .....	45
<b>6.</b>	<b>Troubleshooting .....</b>	<b>47</b>
6.1	MK800 error messages .....	47
6.2	Malfunctions .....	49
<b>7.</b>	<b>Operation .....</b>	<b>51</b>
7.1	Operator control and display elements .....	51
7.2	Quick reference guide .....	53
7.2.1	Display under normal operating conditions .....	53
7.2.2	Display during fault condition .....	53

7.2.3 Test function .....	55
<b>8. Menu mode: Operation and setting .....</b>	<b>57</b>
8.1 Switching on and calling the main menu .....	57
8.2 Menu overview diagram .....	59
8.3 Main menu functions .....	60
8.4 The main menu .....	60
8.4.1 Exit .....	60
8.4.2 Menu 2: Measured values .....	60
8.4.3 Menu 3: History .....	61
8.4.4 Menu 4: Settings .....	63
8.4.4.1 Exit .....	64
8.4.4.2 Settings menu 2: Alarm addresses .....	64
8.4.4.3 Settings menu 3: Test addresses .....	65
8.4.4.4 Settings menu 4: Value addresses .....	66
8.4.4.5 Settings menu 5: Digital inputs .....	67
8.4.4.6 Settings menu 6: Buzzer (and LED) .....	69
8.4.4.7 Settings menu 7: Common reset .....	69
8.4.4.8 Settings menu 8: Clock .....	70
8.4.4.9 Settings menu 9: Language .....	71
8.4.4.10 Settings menu 10: Interface .....	72
8.4.4.11 Settings menu 11: Relays .....	73
8.4.4.12 Settings menu 12: Password .....	74
8.4.4.13 Settings menu 13: Service menu .....	74
8.4.5 Menu 5: Control .....	75
8.4.5.1 Exit .....	75
8.4.5.2 Control menu 2: Reset (AlarmClear) .....	75
8.4.5.3 Control menu 3: EDS Start/Stop .....	76
8.4.5.4 Control menu 4: Test communication .....	76
8.4.5.5 Control menu 5: Reset mode .....	77
8.4.6 Menu 6: External devices .....	77
8.4.7 Menu 7: Info .....	79
8.5 Overview of setting options .....	80

<b>9. Technical data .....</b>	<b>83</b>
9.1 Technical data .....	83
9.1.1 Standards, approvals and certifications .....	87
9.2 Ordering information .....	87

# 1. How to get the most out of this manual

## 1.1 How to use this manual

This operating manual describes the MK800 alarm indicator and test combination with the software version indicated on the cover page. The functions and processes described may vary from those featured in other versions. This manual is intended for qualified personnel working in electrical engineering and electronics and in particular for those designing, installing and operating electrical equipment in medical locations.

Chapter "Operation" on page 51 can also be used as a quick reference guide by medical personnel.

Before using the devices, please read this operating manual, the supplement entitled "Important safety instructions for Bender Products" and the instruction leaflets supplied with the individual system components. Keep this document in an easily accessible location near to the devices.

Should you have any questions, please do not hesitate to contact. Please contact our Technical Sales Department. We are also happy to provide on-site service. Please contact our Service Department for more information.

Although great care has been taken in the drafting of this operating manual, it may nevertheless contain errors and mistakes. Bender cannot accept any liability for injury to persons or damage to property resulting from errors or mistakes in this manual.

## 1.2 Explanation of symbols and notes

The following terms and symbols are used to denote hazards and instructions in Bender documentation:



**DANGER**

*This signal word indicates that there is a **high risk** of danger that will result in **death** or **serious injury** if not avoided.*



**WARNING**

*This signal word indicates a **medium risk** of danger that can lead to **death** or **serious injury** if not avoided.*



**CAUTION**

*This signal word indicates a **low level risk** that **can** result in minor or **moderate injury** or **damage to property** if not avoided.*



*This symbol denotes information intended to assist the user in making **optimum use** of the product.*



## 2. Safety instructions

### 2.1 Intended use

The universal MK800 alarm indicator and test combination is used for visual and audible indication of operating status and alarm messages from Bender's EDS, RCMS, ATICS<sup>®</sup> and MEDICS<sup>®</sup> systems.

In MEDICS<sup>®</sup> monitoring systems, the MK800 meets the requirements of DIN VDE 0100-710 in respect of test functions for IT system monitoring and alarms from transfer switching devices. IT system monitoring equipment can be tested using the programmable "TEST" button.

Important display functions:

- Normal operation indicator (green LED)
- Insulation fault
- Overload
- Overtemperature
- Messages from EDS... insulation fault location systems and RCMS... residual current monitoring systems
- Interruption of the system conductor or PE conductor connection of the ISOMETER<sup>®</sup>
- Supply line failure
- Power supply fault conditions and transfer switching device faults
- Device failure
- Test results
- Measured values

The clear text display makes information easy to understand. The connection between the MK800 and the changeover and monitoring modules is implemented with bus technology. During normal operation, the MK800 indicates that the system is ready for operation. Version MK800-11 features 16 digital inputs allowing messages from other technical equipment to be recorded and displayed on the MK800, for example from medical gases or battery supported safety power supply systems (BSV systems).

MK800 are used in:

- Medical locations
- Industrial and office buildings
- Public buildings

Please heed the limits of the application area indicated in the technical specifications. Use which deviates from or is beyond the scope of these technical specifications is considered non-compliant.

**Use for intended purpose includes:**

- Device-specific settings compliant with local equipment and operating conditions.
- The observation of all information in the operating manual.
- Compliance with test intervals.

## 2.2 Qualified personnel

Only appropriately qualified personnel may work with the Bender devices. Personnel who are familiar with the installation, commissioning and operation of the equipment and have undergone appropriate training are considered qualified. Personnel must have read this manual and understood all safety-related instructions.

## 2.3 General safety instructions

Bender devices are designed and built in accordance with the state of the art and accepted rules in respect of technical safety. However, the use of such devices may introduce risks to life and limb of the user or third parties and/or result in damage to Bender equipment or other property.

- Only use Bender devices:
  - as intended
  - In perfect working order
  - in compliance with the accident prevention regulations and guidelines applicable at the location of use
- Eliminate all faults immediately which may endanger safety.
- Do not make any unauthorised changes and only use replacement parts and optional accessories purchased from or recommended by the manufacturer of the devices. Failure to observe this requirement can result in fire, electric shock and injury.
- Reference signs must always be clearly legible. Replace damaged or illegible signs immediately.
- Make sure that the dimensions of the BSV (battery-supported safety power supply), the generator set and the whole wiring are adequate. The applicable national and international standards must be observed here. Only in this way selective operation of safety devices can be achieved and a high degree of safety in case of overload and short circuit can be ensured.

## 2.4 Delivery conditions, warranty and liability

The conditions of sale and delivery set out by Bender apply.

Conditions of sale and delivery can be obtained from Bender in printed or electronic format.



### 3. System description

#### 3.1 MEDICS®

The MK800 alarm indicator and test combinations are integral components of the MEDICS® system. MEDICS® is an intelligent system that guarantees safe power supply in medical locations.

**Example of a section of a hospital where a MEDICS® system is installed:**

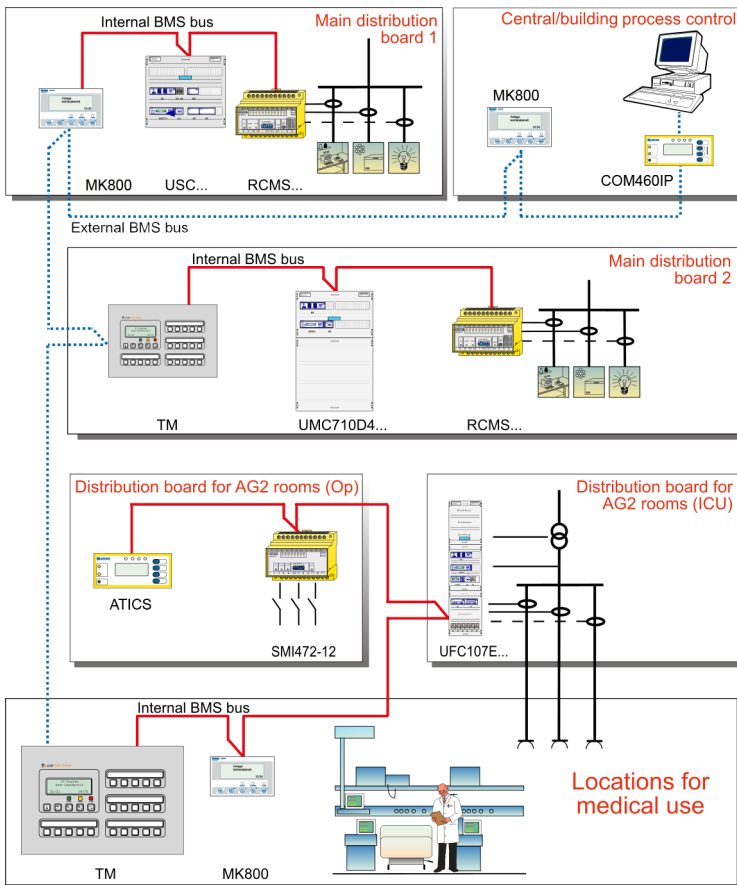

**Legend to illustration above**

MK800	Alarm indicator and test combination
RCMS...	Residual current monitoring systems for TN-S systems
SMI472	Signal converter for third-party systems (e.g. med. gases, BSV systems)
TM...	Alarm indicator and operator panel
UFC107E...	Changeover and monitoring module for IT systems with insulation fault location system EDS...
UMC107E...	Changeover and monitoring module for IT systems
UMC710D...	Changeover module for main distribution boards
USC710D...	Control module for changeover modules (preferably in main distri- bution boards)
ZLT	Central Control Technology
GLT	Building Control Systems

**MEDICS<sup>®</sup> includes:**

- Display and operating units such as TM... alarm indicator and operator panels or MK... alarm indicator and test combinations
- Single and three-phase monitoring modules. MEDICS<sup>®</sup> system modules are, for example: UMC..., USC..., UFC... as well as EDS... insulation fault location systems
- Communication between these components via the BMS bus (two-wire connection).
- The connection of third-party technical systems by means of protocol converters (gateways) or via digital inputs and relay outputs.

The real strength of MEDICS<sup>®</sup> is to be found in communication between all involved components and the resulting information provided to the user. The functionality of the equipment is continuously monitored. Operating states, irregularities, faults and equipment failures are displayed. This means high operational reliability and high availability of the installation for the user.

### 3.2 Characteristics

On its backlit display (4 x 20 characters), the MK800 displays messages from all BMS bus devices assigned via alarm addresses. As well as being used as a standalone indicator, the MK800 can also be used as parallel indication of several MK800 in different rooms. In the event of an alarm message, the yellow "WARNING" LED or the red "ALARM" LED lights up and the message appears on the LC display in plain text format. At the same

time there is an audible signal (can be acknowledged/muted). If a second message is received whilst the first is still pending, the audible signal will sound again and the messages will appear alternately on the LC display. In addition, the address of the device triggering the alarm can be called up. The audible signal sounds again once a configurable period of time has elapsed (repetition can be deactivated).

Internal device parameters (alarm addresses, test addresses...) and also the parameter setting of EDS and RCMS systems can be accessed via the menu system. MK800 can be used as a master device in installations with several IT and EDS systems.

The "TEST" button can be used to check the function of the associated devices such as insulation monitoring devices, LIM (Line Isolation Monitors) or GFCI (Ground Fault Circuit interrupters). The message is only available on the MK800 on which the button "TEST" was pressed. The test and its individual evaluations are carried out sequentially. Finally a message appears indicating either a successful test or a fault.

#### **MK800 feature:**

- Display of operating status, warning and alarm messages in accordance with DIN VDE 0100-710, IEC 60364-7-710 and other standards
- Backlit clear LC text display (4 x 20 characters)
- Standard texts for messages selectable in 21 national languages
- 1000 freely programmable message texts (with TMK-SET PC software)
- Bus technology for easy installation and reduced fire load
- Audible alarm (can be acknowledged or muted)
- Menu-based setting (German/English): MK800 basic parameters and via BMS bus: EDS46x, EDS47x, EDS49x, RCMS460, RCMS470, RCMS490
- Types available for flush and surface mounting
- Easy commissioning due to predefined alarm text messages
- 16 digital inputs (MK800-11 only)
- History memory with real-time clock to store 1000 warning and alarm messages

### 3.3 Functionality

#### 3.3.1 Display/operating elements

The backlit display features 4 lines of 20 characters each. It assists medical and technical personnel during the decision-making process with information that is always clear and unambiguous. Every alarm message comprises three lines which appear spontaneously and three additional lines which can be displayed at the touch of a button. The fourth line contains status information (the number of messages, test procedures, menu information). Below the text display, three LEDs are arranged. They indicate:

Normal operation (green), warnings (yellow) or alarms (red).

Five buttons are available to acknowledge or to mute alarm and warning messages, for testing the assigned devices and for the menu system.

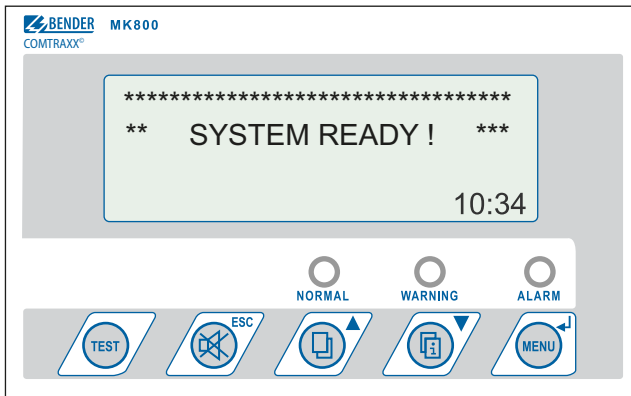

#### 3.3.2 Programmable messages

Standard message texts can be activated by enabling alarm addresses. These texts are available in 21 national languages. Alarm addresses can be enabled via the device menu system (without personal computer). Individual message texts each comprising 6 lines à 20 characters can be programmed with the TMK-SET PC software.

An LED (yellow or red) and an audible signal can be assigned to each message. For this purpose, the PC is connected to the USB interface or BMS bus (RS-485).



### 3.3.3 History memory

Warnings and alarms are automatically written to the history memory with date and time stamp. 1000 text messages can be stored. Each subsequent message overwrites the oldest message (message 1001 will overwrite message 1 etc.). The history memory can be read out via the operating menu or the TMK-history PC software.

## 3.4 Versions

### 3.4.1 MK800-12

The MK800-12 is used for visual and audible indication of alarms from Bender EDS, RCMS and MEDICS<sup>®</sup> systems and for testing assigned devices (insulation monitoring devices, LIM, GFCI). Furthermore, the MK800-12 can be used as parallel indication in conjunction with MK800-11 and SMI472-12. The programmed message texts are displayed on the LCD in the selected national language.

### 3.4.2 MK800-11

The MK800-11 features all the functions of the MK800-12. In addition, the MK800-11 provides 16 digital inputs and a programmable relay output.

All digital inputs, divided into four groups of 4, are galvanically isolated from each other. The input voltage is AC/DC 10...30 V/2...5 mA (HIGH = 10...30 V; LOW=0...2 V). In practice, these digital inputs (IN1...IN16) are controlled via an internal or external voltage and potential-free contacts (N/C or N/O operation configurable). The voltage required for these inputs is provided via the power supply unit, which also supplies power to the MK800. Any message text can be assigned to the inputs.

### 3.4.3 Interfaces

MK800 feature

- an internal BMS bus,
- an external BMS bus
- and a USB interface.

### 3.4.3.1 Internal BMS bus

The internal BMS bus is used for communication with BMS bus devices,

- e.g. modules like UMC..., UMA... , UFA..., UFC..., LFC..., ATICS
- or devices like RCMS..., EDS..., SMI..., SMO..., alarm indicator and operator panels

The MK800 is the master whenever the address is set to 1.

An address setting of 2...150 denotes operation as a slave. This setting is only possible when the external BMS bus is disconnected.

The master is responsible for specific tasks:

- as a "master clock", it synchronises the time of all devices on the internal BMS bus;
- it controls the data traffic on the BMS bus.

### 3.4.3.2 External BMS bus

The external BMS bus is used as a coupling between alarm indicator and operator panels, MK800 and central data recording devices via SMI472-12.

The device with address 1 (master) synchronises the time of all devices on the external BMS bus as "master clock".

The master function is cyclically passed starting from address 1.

### 3.4.3.3 USB interface

A PC can also be connected to the MK800 via the USB interface with a USB cable (Type A plug onto Type B plug). To access the interface, the MK800 has to be removed.

Only the connected MK800 can be read out and set via the USB interface.

## Programming and reading the MK800

Connect the MK800 to a PC:

- directly via the USB interface or
- via an RS-232/RS-485 converter DI-2 or a USB/RS-485 converter DI-2USB to the internal or external BMS bus.

You can use the optional TMK-SET PC software to display and change the MK800 settings.

The optional PC software TMK history can be used to read out the MK800.

## 4. Installation and connection

### 4.1 Installation

#### Overview of enclosure variants

The **MK800** is suitable for flush-mounting as well as for installation in a control panel or cavity wall.

The **MK800E** is only suitable for panel mounting without rear cover.

The **MK800A** and **MK800AF** in the surface-mounting enclosure are suitable for surface mounting.

#### 4.1.1 Flush-mounting

##### Dimension diagram flush-mounting enclosure UP800

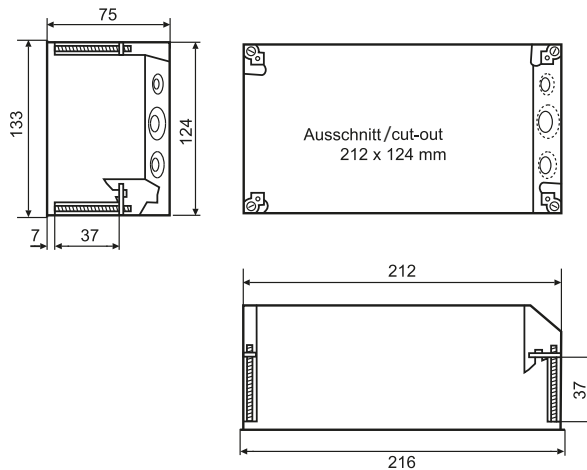

Fig. 4.1: MK800 in the flush-mounting enclosure. Dimensions in mm.  
The MK800 is fixed to its enclosure with four screws.

## Flush-mounting

1. Insert the cardboard that has been supplied into the flush-mounting enclosure to stabilise the enclosure and to provide protection against pollution during mounting.
2. Insert the enclosure so that it is flush with the wall surface. The flush-mounting enclosure must not be installed lopsidedly or warped, and must not be installed too deep below the surface.

### 4.1.2 Cavity wall mounting

The flush-mounting enclosure is included in the scope of delivery of MK800-11/MK800-12.

#### Dimension diagram flush-mounting enclosure

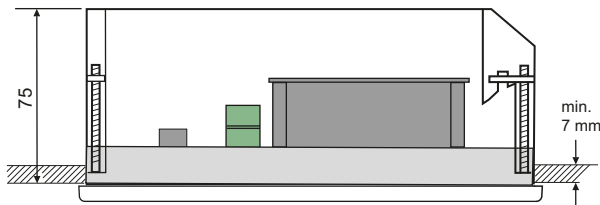

*Fig. 4.2: Dimension diagram of MK800-11/MK800-12 with bezel frame BR800 and flush-mounting enclosure UP800. Dimensions in mm. Example: Cavity wall mounting*

### Cavity wall mounting

1. Make a cutout in the cavity wall of the exact size of the flush-mounting enclosure (212 x 124 mm)
2. Insert and fix flush-mounting enclosure with screws
3. Insert and fix MK800 with four screws
4. Optional: Place bezel frame on top (refer to page 23)

### 4.1.3 Control panel mounting without enclosure

For mounting in panels/doors the MK800 can also be delivered without enclosure: Version MK800E... (refer to "Ordering information" on page 87).

#### Dimension diagram MK800E...

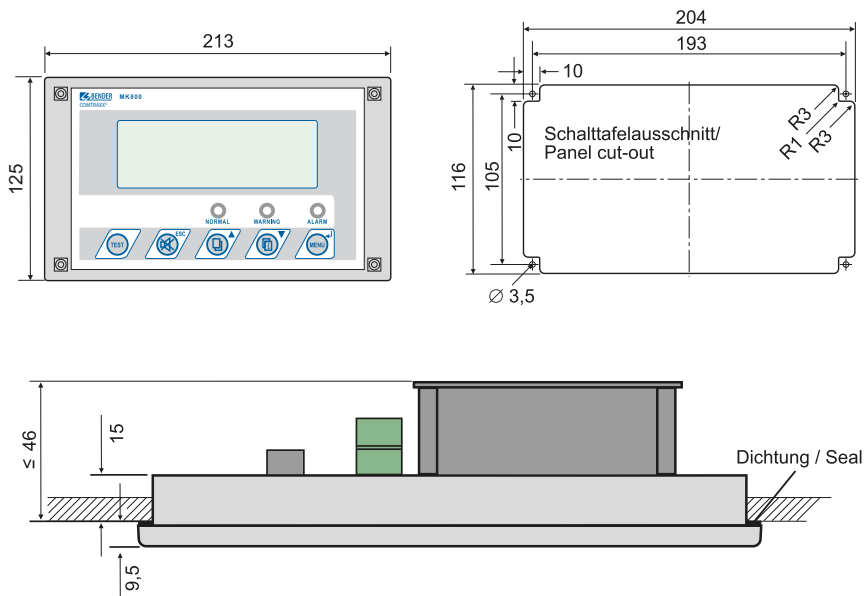

Fig. 4.3: Dimensions in mm.  
Example: Door mounting

#### Mounting in panel without enclosure

1. Make front panel cut-out and drilling holes as described in the sketch
2. Insert MK800 in the cut-out from the outside
3. Fix MK800 with four screws (not included in the scope of delivery) to front panel
4. Optional: Place bezel frame on top (refer to page 23)

#### 4.1.4 Control panel mounting with enclosure

The MK800 can be protected by an enclosure also when it is inserted in a control panel:

##### Dimension diagram MK800 with flush-mounting enclosure UP800

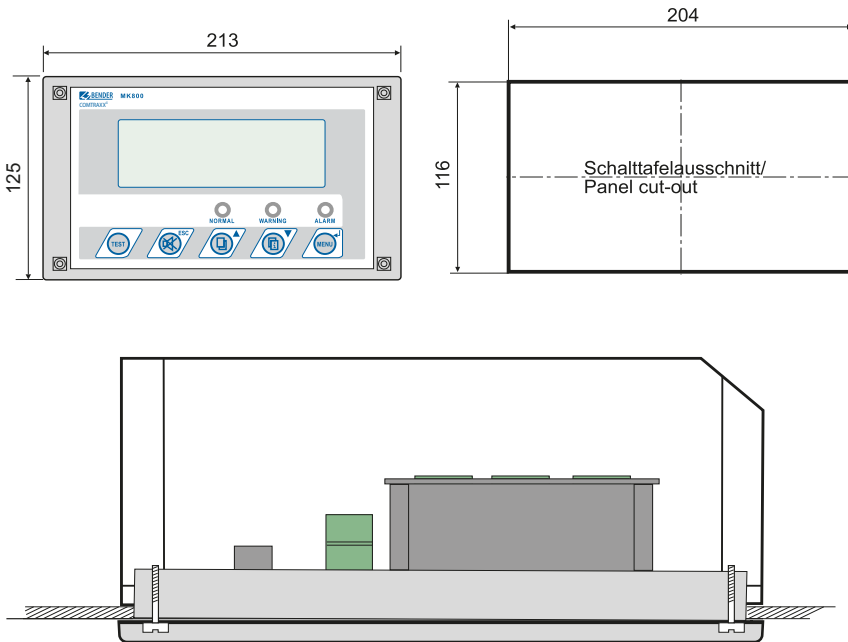

Fig. 4.4.: Dimensions in mm.

Example: Door mounting with flush-mounting enclosure

#### Control panel mounting with enclosure

1. Make front panel cut-out as described in the sketch
2. Insert MK800 in the cut-out from the outside
3. Hold flush-mounting enclosure correctly against the rear side of the MK800
4. Fix MK800 to flush-mounting enclosure with four screws
5. Optional: Place bezel frame on top (refer to page 23)

#### 4.1.5 Use bezel frame

The MK800 can optionally be covered with a bezel frame. This frame is not included in the scope of delivery and has to be ordered separately (refer to "Ordering information" on page 87).

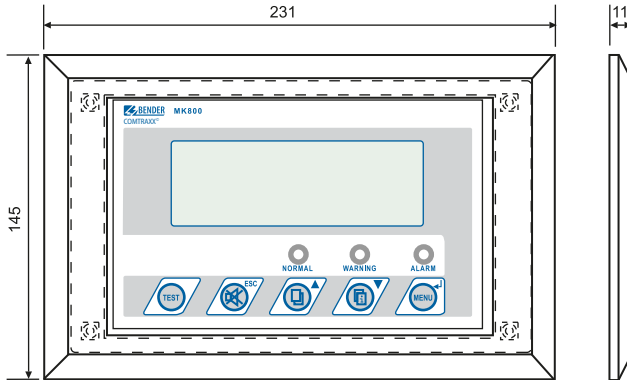
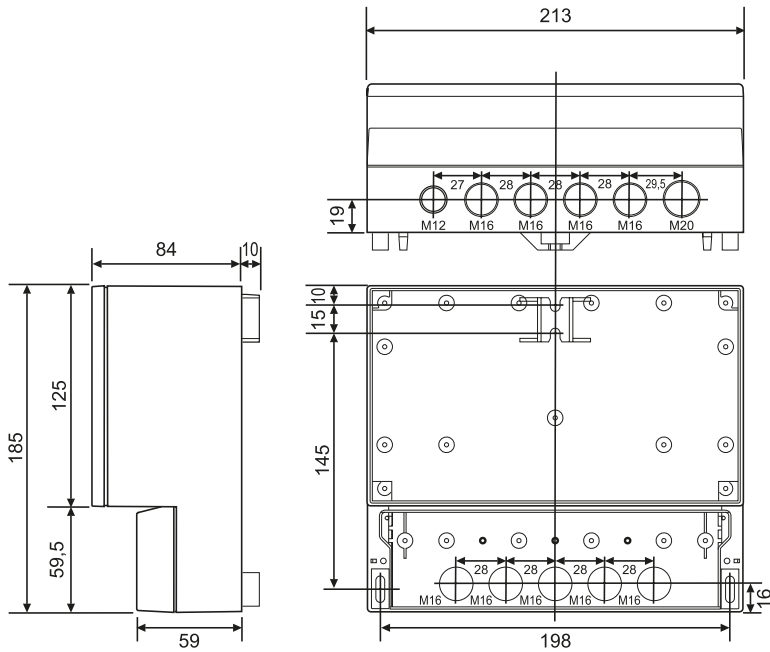

*Fig. 4.5: Dimension diagram MK800 with bezel frame*

After mounting the MK800, the bezel frame is attached to the front of the device.

### 4.1.6 Surface-mounting enclosure

#### Dimension diagram surface-mounting enclosure MK800A-11/MK800A-12





## Dimension diagram surface-mounting enclosure with door MK800AF-11/ MK800AF-12

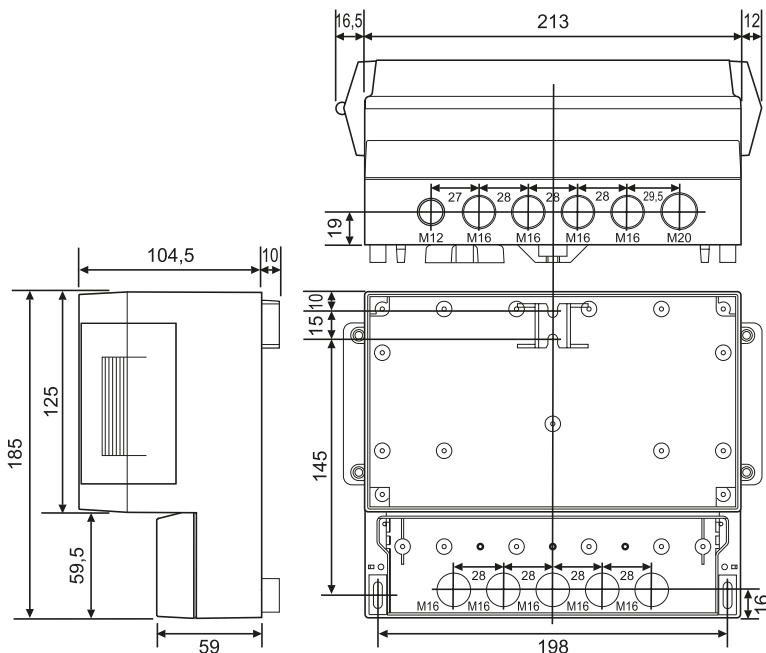

### Installation of the surface-mounting enclosure



*A smooth and even surface is a precondition for installation. Only the fastening screws specified below should be used. Failure to observe this can result in deformation or damage to the enclosure.*

1. Use the empty enclosure as a template for marking the drilling holes. Make the drilling holes in accordance with the material of the subsurface.
2. Fix the empty enclosure with screws. Maximum diameter of the screws: Thread 3 mm, bolt head 7 mm
3. Only in MK800AF: Connect aluminium front panel to the protective conductor (PE).
4. Fix MK800 to the enclosure with screws.

## 4.2 Connection



DANGER

### **Risk of electric shock!**

Before fitting the enclosure and working on the device connections, make sure that the power supply **has been disconnected**.

Failure to comply with this requirement will expose personnel to the risk of an electric shock. Furthermore, the electrical installation may be damaged and the device may be destroyed beyond repair.



DANGER

Connect the MK800 exclusively according to the wiring diagram in this chapter. Do not make **any changes to the internal wiring**. Non-compliant connection or arbitrary changes can lead to serious malfunctions or even the complete failure of the MK800.



CAUTION

Make sure that the power supply of the MK800 is **isolated from PE**. If this is not taken into consideration and a PC is connected to the USB interface, the MK800 device and the PC may be damaged.



CAUTION

The device contains components that can be damaged by **electrostatic discharges (ESD)**. When work activities are carried out when the device is open, the safety precautions concerning the dissipation of electrostatic electricity have to be observed.

#### 4.2.1 Connection details

- Connect the MK800 to the supply voltage  $U_S$  (terminals +/-).
  - If you are connecting the MK800 to a DC 24 V supply:  
Take the line voltage drop into account if you are using long supply cables for the supply voltage.
  - Consider the maximum permissible cable lengths for the supply voltage  $U_S$  when using an AN450 or AN410 power supply unit (refer to "Technical data").
- Connect the internal and external BMS bus according to the instructions in the "BMS bus" leaflet.  
Use a shielded and twisted cable with a diameter of at least 0.8 mm for the interface line (e.g. J-Y(St)Y n x 2 x 0.8). The shield must be connected to earth at one end. Please note that, when routing the supply voltage  $U_S$ , a 4-wire cable (2 x BUS, 2 x  $U_S$ ) with suitable cross section is required.
- Use the DIP switches S1 and S2 to set the terminating resistor for the internal and external BMS bus: S1 = external BMS bus; S2 = internal BMS bus. Factory setting S1 and S2: off.
- MK800-11 only: Use cables with a cross section of at least 0.75 mm<sup>2</sup> when connecting the digital inputs and the relay output. The maximum cable length per connection is 500 m.

4.2.2 Wiring diagram

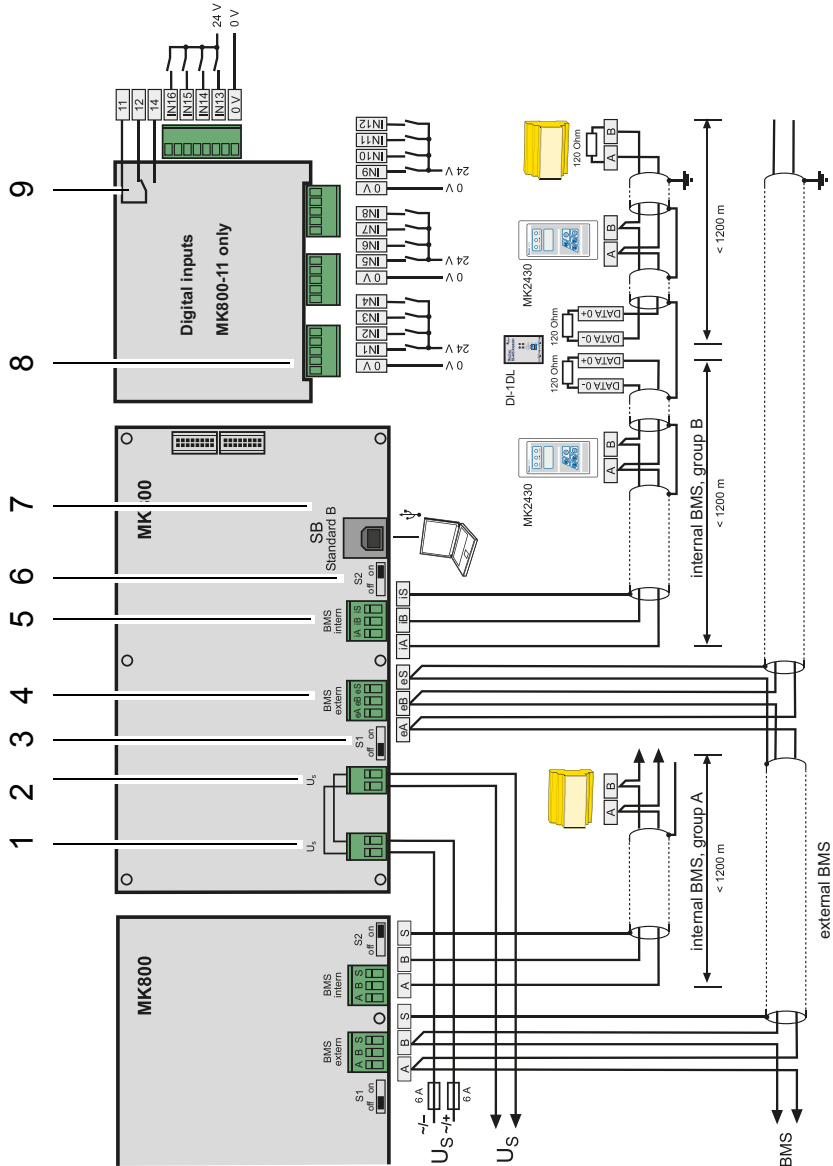

## Legend to wiring diagram

1	<p>Supply voltage <math>U_S</math> (see „Technical data“ on page 83.)</p> <p><b>Note: Make sure that the power supply of the MK800 is isolated from PE. If this is not taken into account and a personal computer is connected to the USB interface, the MK800 device and the PC may be damaged.</b></p> <p>In MK800AF only: Connect aluminium front panel to the protective conductor (PE).</p>
2	Looped through connection for supply voltage (e.g. for control voltage relay contacts)
3	<p>Switch S1 to terminate the external BMS bus.</p> <p>If two or more devices are connected to each other via the BMS bus, the bus line must be terminated at both ends with a resistor (<math>R = 120 \Omega</math>).</p>
4	External BMS bus connection. The external BMS bus is primarily used for the connection of several MK800 or TM800. SMI472-12 signal converters can also be connected.
5	Internal BMS bus connection. Various Bender devices with a BMS bus interface can be connected to the BMS bus. These may include: Insulation monitoring devices 107TD47, control devices PRC487, residual current monitors RCMS470 and many more.
6	<p>Switch S2 to terminate the internal BMS bus.</p> <p>If two or more devices are connected to each other via the BMS bus, the bus line must be terminated at both ends with a resistor (<math>R = 120 \Omega</math>).</p>
7	USB interface. For PC connection. The TMK-SET PC software is used to program the MK800. You can use the PC software TMK-HISTORY to read out the MK800 history memory.
8	MK800-11 only: Digital inputs. The digital inputs can be controlled by an internal or external voltage and potential-free contacts. If the inputs are controlled via an external voltage, the common 0(-) is applied to terminal "0 V" and the 1(+) signal to the corresponding input IN1...IN16.
9	MK800-11 only: Relay output. Programmable contact for device errors, test of assigned devices, device failure, common alarm message, buzzer

#### 4.2.2.1 Connection assignment MK800-12

The MK800-12 edition receives all messages from the BMS bus. These messages can be received, for example, from an 107TD47, an MK800-11, a signal converter SMI47x, an EDS... or a RCMS....

$U_S$	Supply voltage $U_S$ : looped through connection for supply voltage $U_S$ . <b>Note: Make sure that the power supply of the MK800 is isolated from PE. If this is not taken into consideration and if a personal computer is connected to the USB interface, the MK800 device and the PC may be damaged.</b>
eA, eB, eS	External BMS bus with shield S
iA, iB, iS	Internal BMS bus with shield S
USB	USB connection. Cable: type A plug on type B plug.
S1, S2	Switch S1 to terminate the external BMS bus and switch S2 to terminate the internal BMS bus.

#### 4.2.2.2 Connection assignment MK800-11

The MK800-11 alarm indicator and test combination provides additional terminal strips for the 16 digital inputs and one optional relay output.

IN1...IN16	Digital inputs 1...16
0 V (IN1...4)	Common connection "0" for digital inputs 1...4
0 V (IN5...8)	Common connection "0" for digital inputs 5...8
0 V (IN9...12)	Common connection "0" for digital inputs 9...12
0 V (IN12...16)	Common connection "0" for digital inputs 12...16
11, 12, 14	Relay output

### 4.2.3 Examples for BMS bus connection and addressing



*Missing or incorrectly installed terminating resistors (e.g. in the middle of the bus) will cause bus instability. Please also note the information in the "BMS bus" operating manual.*

#### Example 1: Operating theatre and intensive care unit with two IT systems and three rooms

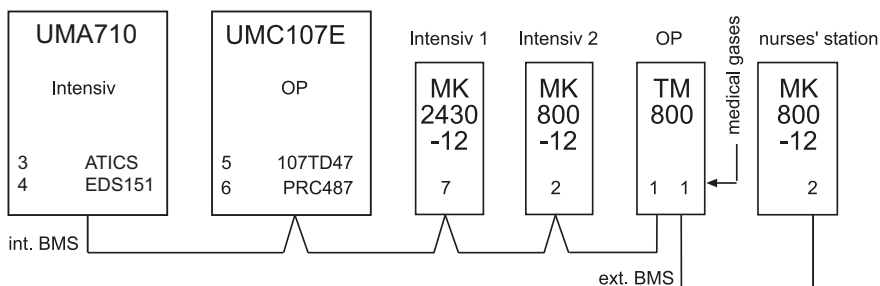

The alarm indicator and test combinations MK... in the intensive care unit 1 and 2 indicate the alarm messages of the corresponding MEDICS® module UMC107E as well as the alarm messages of the medical gases.

The TM800 records the alarm messages of the medical gases via the digital inputs. In addition, the TM800 indicates the alarm messages of the corresponding MEDICS® module UMC107E (Operating theatre).

The alarm indicator and test combination in the nurses station indicates all alarm messages and monitors all devices for failure. On this MK... a test of all connected insulation monitoring devices can be started.

Device	Parameters	Int. BMS bus address	Ext. BMS bus address
First changeover device UMA710			
ATICS	Bus address	3	--
EDS151	Address	4	--
Second changeover device UMC107E			
107TD47	Bus address	5	--
PRC487	Address	6	--
Alarm indicator and test combinations			
MK2430-12 (Intensive care unit 1)	Address	7	--
	Test address	3	--
	Alarm address	3	--
	Individual alarm address	4*	
MK800-12 (Intensive care unit 2)	Address	2	from
	Test address	3	--
	Alarm address	3	--
	Individual alarm address	4*	
TM800 (Operating theatre)	Address	1	1
	Test address	5	--
	Alarm address	5, 6	--
MK800-12 (Nurses station)	Address	from	2
	Test address		ext./int.: 1/3, 1/5
	Alarm address		ext./int.: 1/0**, 1/2, 1/3, 1/5, 1/6, 1/7
	Individual alarm address		1/4*



### Example 2: Intensive care area with two IT systems and four rooms

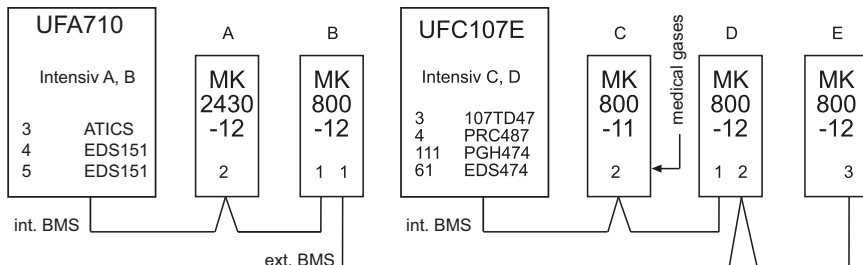

The alarm indicator and test combinations MK... in the intensive care units A and B or C and D indicate all alarm messages of the corresponding MEDICS<sup>®</sup> module UFA710 or UFC107E. On this MK... a test of all corresponding insulation monitoring devices can be started.

The MK800-11 (C) records the alarm messages of the medical gases via the digital inputs. The MKs B, C, D and E indicate the alarm messages of the medical gases.

The MK800-12 (E) allows monitoring of the entire installation. It indicates all alarm messages and monitors all devices for failure. On this MK... a test of all connected insulation monitoring devices can be started.

Device	Parameters	Int. BMS bus address	Ext. BMS bus address
Changeover and monitoring module UFA710 (Intensive care unit A, B)			
ATICS	Bus address	3	--
EDS151	Address	4	--
EDS151	Address	5	--
Changeover and monitoring module UFC107E (Intensive care unit C, D)			
107TD47	Bus address	3	--
PRC487	Address	4	--
PGH474	Address	111	--
EDS474-12	Address	61	--

Device	Parameters	Int. BMS bus address	Ext. BMS bus address
Alarm indicator and test combinations			
MK2430-12 (Intensive care unit A)	Address	2	--
	Test address	3	--
	Alarm address	1, 3, 4, 5	--
	Individual alarms	61*	--
MK800-12 (Intensive care unit B)	Address	1	1
	Test address	3	--
	Alarm address	2, 3, 4, 111	2/2
	Individual alarms	4*, 5*	--
MK800-11 (Intensive care unit C)	Address	2	from
	Test address	3	--
	Alarm address	1, 3, 4, 111	--
	Individual alarms	61*	--
MK800-12 (Intensive care unit D)	Address	1	2
	Test address	3	--
	Alarm address	2, 3, 4, 111	--
	Individual alarms	61*	--
MK800-12 (Monitoring E)	Address	--	3
	Test address	--	ext./int.: 1/3, 2/3
	Alarm address	--	ext./int.: 1/0**, 1/2, 1/3, 1/4, 1/5, 2/0**, 2/2, 2/3, 2/4, 2/111,
	Individual alarms	--	1/4*, 2/61*

### Explanatory notes to example 1 and example 2:

\* Program individual messages for each EDS channel.

\*\* refer to the following chapter „4.2.4 Address settings and their meaning“.

#### 4.2.4 Address settings and their meaning

Display		Meaning	Setting on TM/MK800	Setting in TMK-SET
External address	Internal address			
0 (ext bus on)	0	--	--	--
0 (ext bus on)	1	TM/MK itself	--	dig. IN*
0 (ext bus off)	M = own addr.	TM/MK itself	--	dig. IN*
0 (ext bus off)	M <> own addr.	Device M on int. bus of the own device	ext: 0/int: M	int. bus: int M
N = own addr.	0	Device N on ext. bus	--	dig. IN*
N = own addr.	1	TM/MK itself	--	dig. IN*
N = own addr.	M > 1	Device M on int. bus of the own device	--	int. bus: int M
N <> own addr.	0	Device N on ext. bus	ext: N/int: 0	ext. bus: ext: N, int: 0
N <> own addr.	1	Device N on ext. bus	--	ext. bus: ext: N, int: 0
N <> own addr.	M > 1	Device M on int. bus of the device N	ext: N/int: M	ext. bus: ext: N, int: M

### Explanatory notes to digital inputs (only MK800-11)

Alarm messages from digital inputs on TM/MK800 are always displayed on the device itself regardless of whether an individual message has been programmed or not (exception: the channel is deactivated).

An entry into the alarm address table is not required.

- If no individual message is programmed, the standard text will be displayed.
- An alarm message can also be programmed to be displayed without text/LED/buzzer (**silent message**).
- **Note: Flashing alarm messages are not allowed!**

In principle, all alarm messages are stored in the history memory (Exception: channel is deactivated):

- If no individual message is programmed, the standard text will be displayed or stored in the history memory.
- If the message has been programmed without a text (silent message), its source (DigIn or address and channel no.) will be stored in the history memory (no individual text possible!).
- TEST messages are only stored in the history memory of the device that triggered the message.

Transmission via BMS bus:

All alarm messages are actively sent (i.e. as a new message) via the external or internal BMS.

Operating messages are actively sent via the external BMS bus and are not stored in the history memory.

- Note: Flashing messages must be avoided where possible, and on no account be signalled via the int./ext. BMS bus!
- The first 16 digital inputs can be configured as "flashing" and in this case are not signalled via the external BMS. This is only permissible for messages with a flashing frequency of 0.5 Hz!

Inputs that are assigned to operating messages or switching commands are not displayed with a text message or stored in the history memory.

## 5. Commissioning and testing

Start commissioning according to the following commissioning pattern:

1. Tests before switching on
2. Tests after switching on
3. Set parameters (parameterisation)
  - Settings at the MK800
  - Settings in the TMK-SET software
4. Tests after parameter setting



*Write down all settings and keep it together with the device and installation documentation.*

*When setting the MK800 with the configuration software TMK-SET, a project file is created. Save this file. Create a backup copy of this file and keep it in a safe place.*

## 5.1 Tests before switching on

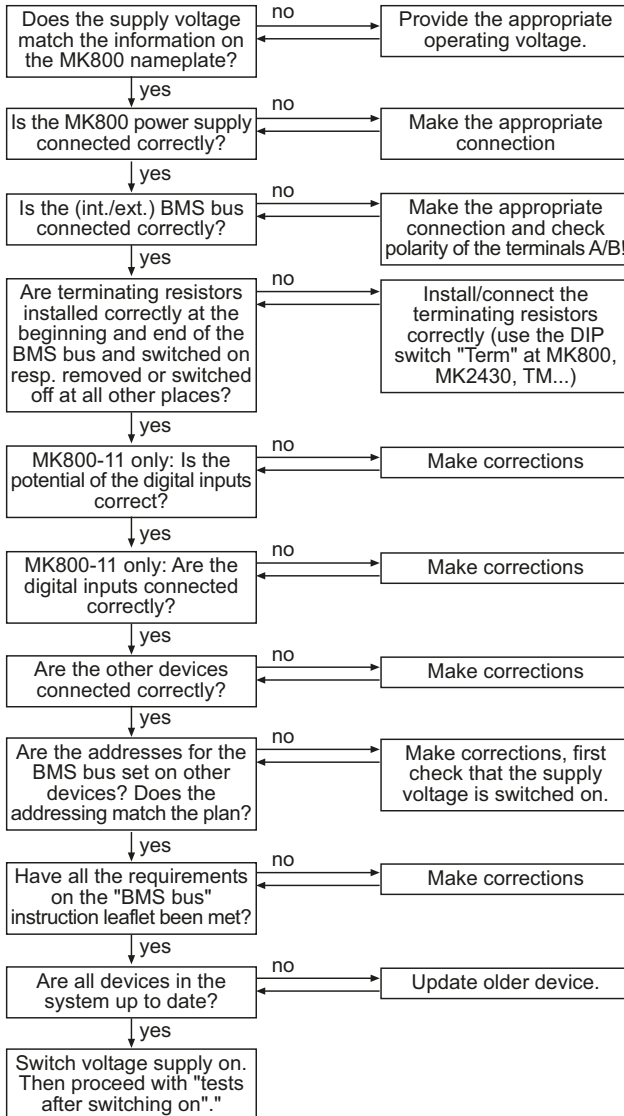

Continue with chapter „5.2 Tests after switching on“

## 5.2 Tests after switching on

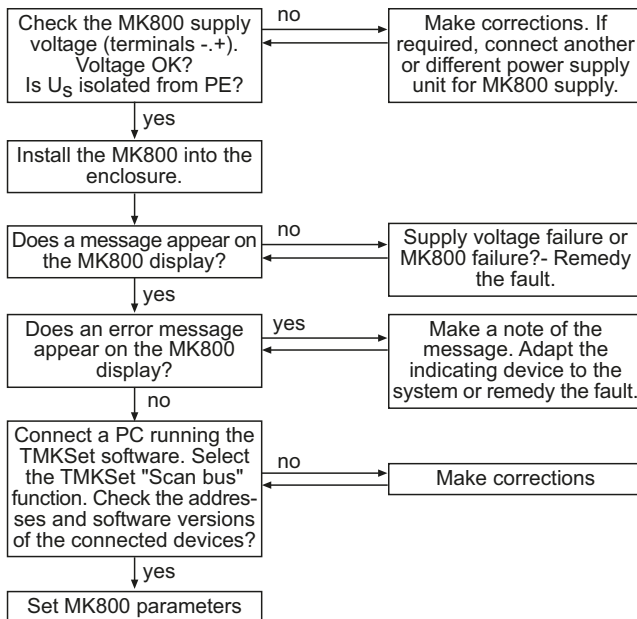

Continue with chapter „5.3 Make settings (parameterisation)“

## 5.3 Make settings (parameterisation)



**All settings can be carried out via the TMK-SET software. Alternatively, some settings can be carried out via the MK800 menu (see diagrams).**

### 5.3.1 Settings on the MK800

For details refer to "Menu 4: Settings" on page 63.

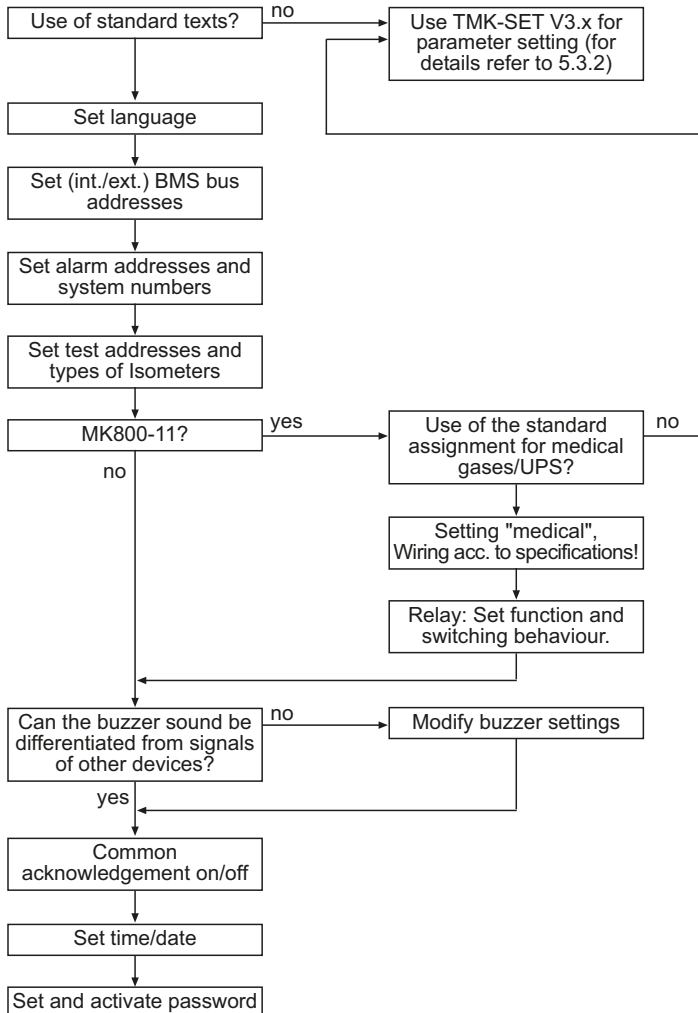

Continue with chapter „5.3.3 Tests after parameter setting“



### 5.3.2 Settings using the TMK-SET software

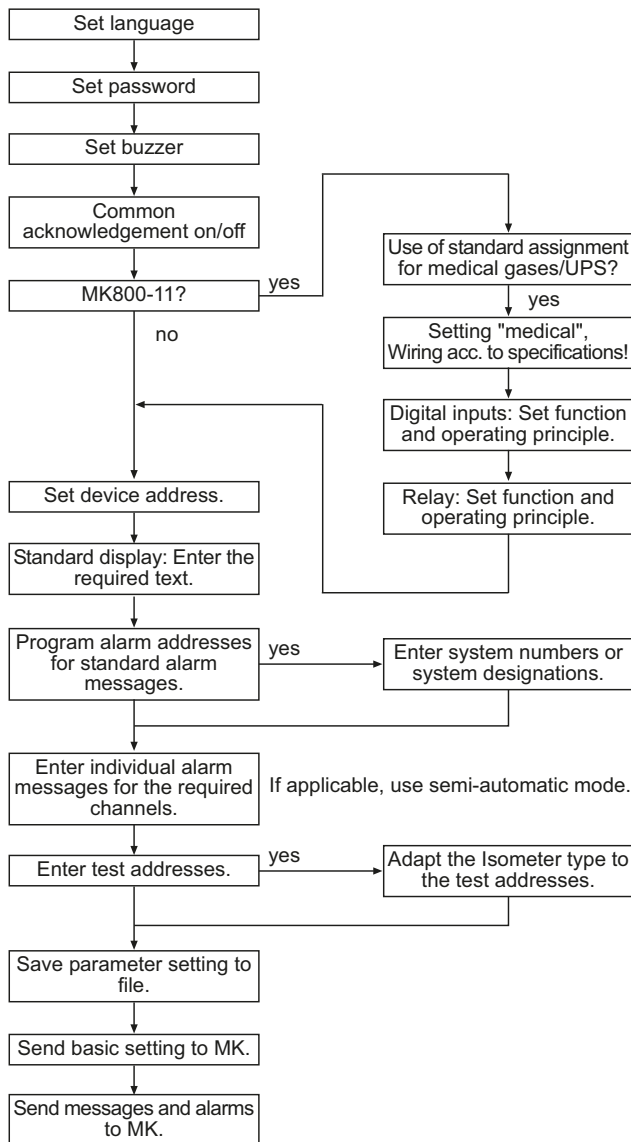

Continue with chapter „5.3.3 Tests after parameter setting“

### 5.3.3 Tests after parameter setting

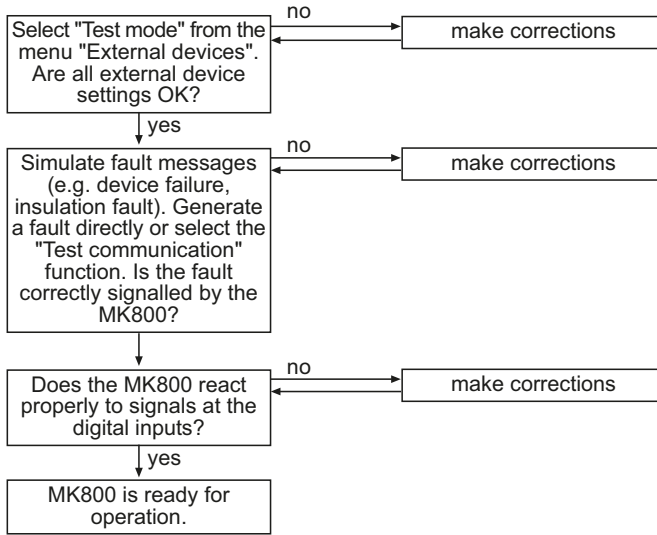

(\*) Messages which can be created by a BMS device are simulated.

## 5.4 Periodic verification and service

### 5.4.1 Periodic verification

The following periodic verification must be performed on electrical installations in compliance with the local or national regulations that apply. For your Bender products, we recommend:

Task	By	Interval
Functional test of IT system monitoring (insulation, load current, transformer temperature and connection monitoring) by pressing the "TEST" button on the alarm indicator and test combination or on the alarm indicator and operator panel.	Medical personnel	Once every working day
Functional test of the transfer switching device*: Functional test of the automatic transfer switching devices. Follow the instructions in chapter "Testing of the transfer switching device"!	Electrically skilled person	Once every six months
Functional test of the IT system monitoring (insulation, load current, transformer temperature and connection monitoring) on the insulation monitoring device.	Electrically skilled person	Once every six months
Checking the setting values and the changeover periods	Electrically skilled person	Once every 12 months
Test of the transfer switching device, the IT system monitoring, and the connection to the SCADA system (Supervisory Control and Data Acquisition) (if applicable) and the interaction between the components in the system.  The test includes the following:  - <b>Inspection:</b> Marking, display elements, mechanical components, wiring, parameterisation, connection of third-party systems, evaluation of fault memory - <b>Measurement:</b> Internal/external supply voltages/potentials, bus voltage, bus protocol, bus scan - <b>Testing:</b> Device function, device communication - <b>Documentation:</b> Test results, recommendations for elimination of defects	Bender service	Once every 24 months

\* This test must only be performed by an authorised electrically skilled person in agreement with the medical locations concerned.

Before carrying out the tests, please refer to the instructions relating to the functional tests in the check list. If no national directives apply, you should perform the tests recommended by DIN VDE 0100-710 (VDE 0100-710).

### 5.4.2 Service and support

For commissioning, troubleshooting and periodic verification Bender offers:

#### First Level Support

Technical support by phone or e-mail for all Bender products

- Questions regarding specific customer applications
- Commissioning
- Troubleshooting

Telephone: +49 6401 807-760\*

Fax: +49 6401 807-259

In Germany only: 0700BenderHelp (Telephone and Fax)

E-mail: support@bender-service.com

#### Repair service

Repair, calibration, update and replacement service for all Bender products

- Repair, calibration, testing and analysing of Bender products
- Hardware and software update for Bender devices
- Delivery of replacement devices for faulty or incorrectly delivered Bender devices
- Extended warranty for Bender devices with in-house repair service or replacement device at no extra cost

Telephone: +49 6401 807-780\*\* (technical issues)

+49 6401 807-784\*\*, -785\*\* (commercial issues)

Fax: +49 6401 807-789

E-mail: repair@bender-service.com

Please send the devices for repair to the following address:

**Bender GmbH, Repair-Service, Londerfer Straße 65, 35305 Grünberg**

## Field Service

On-site service for all Bender products

- Commissioning, parameter setting, maintenance, troubleshooting for Bender products
- Analysis of the electrical installation in the building (power quality test, EMC test, thermography)
- Practical training courses for customers

Telephone: +49 6401 807-752\*\*, -762 \*\* (technical issues)  
+49 6401 807-753\*\* (commercial issues)

Fax: +49 6401 807-759

E-mail: [fieldservice@bender-service.com](mailto:fieldservice@bender-service.com)

\*Available from 7.00 a.m. to 8.00 p.m. 365 days a year (CET/UTC+1)

\*\*Mo-Thu 7.00 a.m. - 8.00 p.m., Fr 7.00 a.m. - 13.00 p.m.

**Internet: [www.bender.de](http://www.bender.de)**

### 5.4.3 Maintenance

MK800 does not contain any parts that require maintenance. Despite this, the intervals specified for periodic verification should be adhered to.



## 6. Troubleshooting

### 6.1 MK800 error messages

The following errors are recognised by the MK800 module and indicated on the display. The buzzer emits a beep code corresponding to the error number every 10 seconds. MK800..-11 only: If the function "Device error" has been set in the "Settings menu 11: Relays", the alarm relay will also switch.

No.	Display	Description	Task
1	DISPLAY ERROR	Display defective	Replace the MK800*
2	I2C-BUS ERROR(X)	Error code (X): 1 I <sup>2</sup> C bus error 2 Ack errors when transmitting the address 3 Ack errors when transmitting data 4 Ack errors when receiving the address 5 Ack errors when receiving data 6 Communication problem	Interrupt supply voltage to MK800 for $\geq 3$ minutes. If the error continues to exist, MK800 or I <sup>2</sup> C bus cable is defective -> replace*.
3	RTC ERROR	Clock chip defective	Replace MK800*
4	FLASH ERROR	Memory module D5 defective	Replace memory chip D5 (socketed), replace MK800*
5	Address internal ERROR (XXX)	Address of the MK800 on the internal BMS bus is already in use (XXX=current address)	Change the MK800 address in the menu

No.	Display	Description	Task
6	Overflow ERROR (01)	Permissible number of operating messages on the internal BMS bus has been exceeded. Permissible number: up to version 4.10: 80 version 4.11 and higher: 176	Reduce number of devices that send operating messages at the internal BMS bus.
	Overflow ERROR (02)	Permissible number of operating messages on the external BMS bus has been exceeded.	Program less operating messages which are queried via the external BMS bus.
	Overflow ERROR (03)	More than 80 alarm messages are present. Permissible number: up to version 4.10: 80 version 4.11 and higher: 40	Reduce number of messages
	Overflow ERROR (05)	More than 1000 device failure messages are present	Reduce number of messages
	Overflow ERROR (07)	More than 99 text messages are present	Reduce number of messages
	Overflow ERROR (08)	Automatic correction of the history memory is carried out because of voltage interruption.	None
	Overflow ERROR (11)	Stack Error	Write down the error code and contact Bender Service.
7	Checksum ERROR	Program memory defective	Replace MK800*
8	Address external ERROR (XXX)	Address of the MK800 on the internal BMS bus is already in use (XXX=current address)	Change the MK800 address in the menu
9	I2C-0-Error	I <sup>2</sup> C-Bus-Interrupt	Replace MK800*



No.	Display	Description	Task
10	I2C-1-Error	I <sup>2</sup> C-Bus-Interrupt	Replace MK800*

\* Please write down the error, the error number and if applicable the error code. This information facilitates the diagnosis and repair of the device.

## 6.2 Malfunctions

List of possible errors and proposals for elimination of the faults. This error list does not claim to be exhaustive.

Possible error codes occurring after carrying out a test are listed in chapter "Test function" on page 55f.

Errors	Possible cause and actions
MK800 display blank.	Check AC/DC 24 V power supply.
Display is lit up but the screen is empty.	Replace the MK800
Function buttons do not operate.	Replace the MK800
LEDs don't light.	Replace the MK800
Character matrix visible on the display, but firmware doesn't run.	Processor does not start; replace MK800.
Time is reset to zero in case of short-term voltage failure.	Replace the MK800
Error during the transmission of the assignments or basic settings via the USB interface.	MK800 address not properly set (menu); MK800 address does not match setting of TMK-SET configuration software; USB cable defective; wrong serial interface (com port) set in TMK-SET software.
Error on internal BMS bus.	Device addresses on the internal bus incorrectly set; interface cables A/B mixed up; network incorrectly terminated or not at all; incorrect parameter setting with TMK-SET.

<b>Errors</b>	<b>Possible cause and actions</b>
Functional error of the digital inputs.	Digital inputs not correctly set with TMK-SET. Defective connection (does not match pre-assignment). Incorrect setting "neutral/medical".

## 7. Operation

This chapter can also be used by the medical personnel as a quick reference guide.

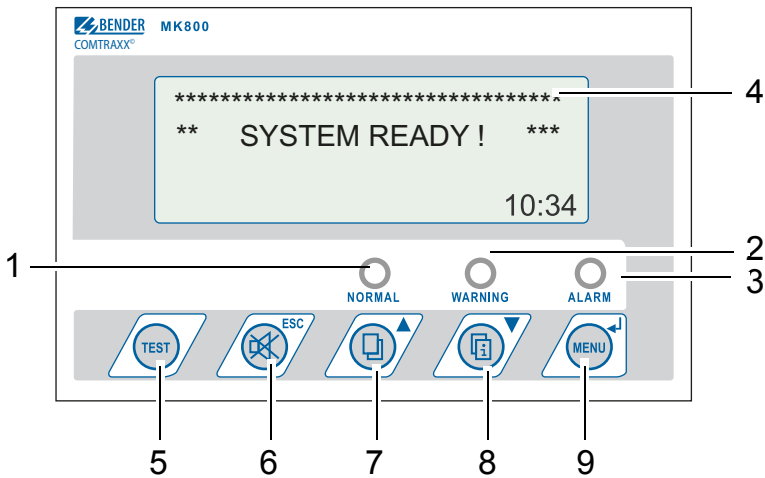

### 7.1 Operator control and display elements



#### LED and LCD

1	LED "NORMAL": Power On indicator, green (only lights up if no warnings or alarms are pending)
2	LED "WARNING": warning messages, yellow
3	LED "ALARM": alarm messages, red
4	LCD: Display of operating status, warning and alarm messages as well as menu functions

**Functions of the buttons:**

	In operating mode	In menu mode
5	"TEST" button Press and release: LED test Press and hold down: Trigger the test of assigned devices (insulation monitoring devices, LIM, GFCI).	No function
6	 button (mute button) Mute the buzzer after an alarm message/acknowledge the alarm	"ESC" button Exit function (without saving) or go up one menu level. When the buzzer is activated, the ESC button will mute the buzzer.
7	 button (scroll) Scroll through the warnings and alarms if there is more than one message pending	Arrow button "▲" to move up in the menu
8	 button (additional text) Toggle between display text and additional alarm text (if available)	Arrow button "▼" to move down in the menu
9	"MENU" button Starts menu mode for setting the MK800; for display and control functions	"↵" button (ENTER button) To confirm the selected menu item

## 7.2 Quick reference guide

The illustrations below serve as examples.

### 7.2.1 Display under normal operating conditions

There are no warnings or alarms pending.

- The green "Normal" LED is lit.
- The LC display shows the programmed standard display.
- A maximum of 3 measuring values can be displayed in lines 1...3.

Example:

Power supply:	OK
Med. gases:	OK
	09:50

- Line 1...3: User-definable standard display text
- Line 4: Status bar, indicates the time of day (can be switched off).

### 7.2.2 Display during fault condition

A warning or an alarm message exists.

- Depending on the type of fault, either the yellow LED "Warning" or the red LED "Alarm" will light up. The green LED "Normal" no longer lights up.
- The buzzer sounds simultaneously. If the cause of fault cannot be remedied immediately, the buzzer can be muted by pressing the "🔇" (6) button.
- The LC display shows details about the message.

Intensive care unit 03	
Insulation fault	
Measured value	43 kΩ
xx/yy [🔇]	zzz 09:50

- Line 1: Standard display: "System:" Enter user-defined text here: "Intensive care unit 03"
- Line 2...3: Message text, measured value (if available)

- Line 4: Status line
  - xx = Consecutive number of message displayed
  - yy = Number of pending messages
  -  = Message text page, in this case page 1
  - zzz = Insulation fault location or test in progress (refer to table)
  - 09:50 = Time (example)

Possible displays during insulation fault location or testing:

zzz	Meaning
EDSa	EDS insulation fault location in progress (automatic)
EDSp	Continuous EDS insulation fault location in progress
EDSs	Single-pass EDS fault location in progress
EDS	EDS insulation fault location process has been completed, the current measuring sequence is still running
TEST	Test is running. The message "TEST" flashes if the message currently displayed has caused the test.

Only when the external bus is in "Off" position:

noMA	No master on the internal bus
MAST	Device is "substitute master" on the internal bus.

Press the button "" (7) to receive further information.

```
since: 25:01:12 16:52
Device:      Isometer
Addr/Ch:    003/01
xx/yy      17:30
```

- Line 1: Date and time the message occurred
- Line 2: Device triggering the message
- Line 3: Address and channel of the device triggering the message

- Line 4:            Status line
  - xx                = Sequence number of the message displayed
  - yy                = Number of pending messages
  -             = Message text page, in this case page 2
  - zzz               = Insulation fault location or test currently in progress (see table)
  - 09:50            = Time (example)



*When the messages are individually programmed, the message text display may vary.*

*If messages are pending and one of the arrow buttons is pressed, the latest message will appear on the display. If no further button is pressed, this message will be displayed for 15 seconds.*

### 7.2.3 Test function

Press and hold down the "TEST" button for at least one second to check the function of the assigned insulation monitoring devices (e.g. 107TD47, IRDH...), LIM (Line Isolation Monitors) and GFCI (Ground Fault Circuit interrupters). The message is only available on the MK800 on which the button "TEST" was pressed.

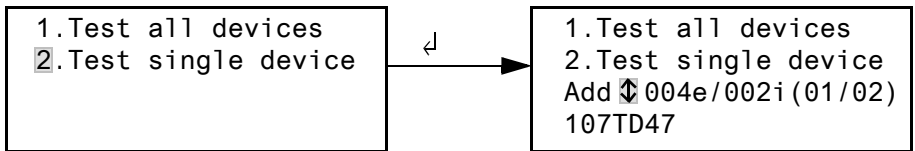

- 1. Test all devices            Tests all devices set in the "test addresses" menu.
- 2. Test single device        Select a device using the arrow buttons and press the "↵" button.

During the tests, the message "TEST" is shown in the status line. The message "TEST" flashes if the message currently displayed has been caused by the test. The associated devices are tested one after another. The MK800 automatically evaluates the messages that appear. Once the process is complete, either a common message about a successful test or an error message is displayed. If more than one device has been tested, a separate error code will be displayed for each device failing the test.

The following error codes are displayed in the event of an Isometer® failing the test:

Error code	Error code description for the 107TD47 ISOMETER® (hospital)	Error code description for the IRDH... ISOMETER® (industry)	Note
0	No messages received from the ISOMETER® although the test command was confirmed by the ISOMETER®.	No messages received from the ISOMETER® although the test command was confirmed by the ISOMETER®.	
1	Only insulation fault message received	Only insulation fault message from channel 1 received	Channel 1
2	Only overload message received	Only insulation fault message from channel 2 received	Channel 2
3	Only insulation fault message and overload message received		Channel 1 and 2
4	Only overtemperature message received		Channel 3
5	Only insulation fault message and overtemperature message received		Channel 1 and 3
6	Only overload message and overtemperature message received		Channel 2 and 3
14	Test command could not be sent because no query was made (slave).	Test command could not be sent because no query was made (slave).	Slave only
15	ISOMETER® did not confirm the test command (no answer).	ISOMETER® did not confirm the test command (no answer).	

### Notes regarding error codes

- For MK800 devices operating as slaves on the BMS bus a timeout of 50 seconds applies to error code 0 and 14.
- Error code 14 occurs when the slave is requested to carry out a test; the test command, however, cannot be sent because MK800 was not queried. This can be the case if the address gap upstream of the MK800 is so large that the master does not query the MK800 (refer to "BMS bus" operating manual). This error code is not so much an indication of a faulty ISOMETER® but that the BMS bus system is faulty.



## 8. Menu mode: Operation and setting

### 8.1 Switching on and calling the main menu

If the MK800 is connected to the power supply, the following information appears on the display for approx. 3 seconds. Details about the address and the firmware version of the device are displayed. This information is also available in the "Info" menu.

```
MK800-11 Addr. : 01/001
Software 4.02   D279
Date:         02/05/12
www.bender.de
```



*If the MK800 has not been turned on for several days, a longer time may be required for start-up (approx. 30 seconds).  
In this case, enter time and date again.*

If there are no messages pending, the standard display will be shown when the starting procedure is completed.

```
*****
*** SYSTEM READY! **
Bender GmbH Grünberg
                09:50
```

The TMK-SET software allows you to change the standard display and the message texts.

Press the button "Menu" to open the main menu.

1. Exit
2. Values
3. History
4. Settings

5. Control
6. External devices
7. Info

The following buttons can be used in the main menu:

ESC	Exit function or go up one menu level
▲, ▼	Select menu items
↵	Confirm the selected menu item (Enter)



*The menu mode is exited automatically if no buttons are pressed in one of the menus for more than five minutes (exception: "test communication" in the "Control" menu and "position mode" in the "External devices" menu).*



*Some menus are password-protected. Password protection is only effective if the password has been enabled (switched on).*

*When an attempt is made to open one of these menus, the password entry screen appears automatically:*

Please enter  
Password  
⏏ 0 0 0

*Once a valid password has been entered, full access will be given to all menus (except to the service menu) until menu mode is exited.*

## 8.2 Menu overview diagram

The following diagram will help you to navigate through the menus:

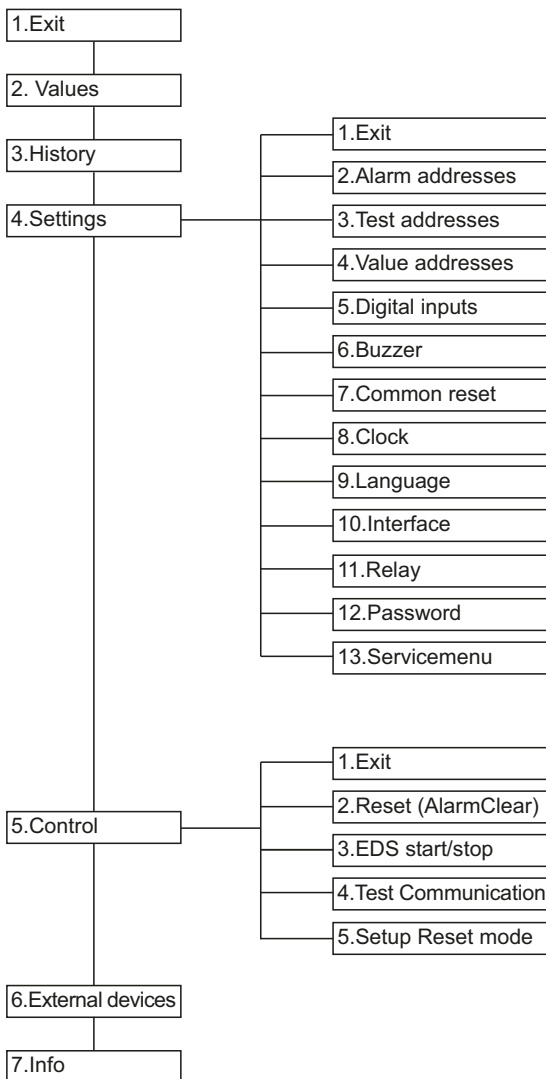

## 8.3 Main menu functions

Menu item	Function	Page
1. Exit	Exit menu mode	
2. Measured values	No function	
3. History	Displays history with information about messages, acknowledgements and associated times.	61
4. Settings	Various settings for this MK800	63
5. Control	This menu offers various options for controlling the overall system.	75
6. External devices	Settings on the connected evaluating devices (e.g. EDS4xx and RCMS4xx).	77
7. Info	Information regarding the device type, the firmware version and the last time the assignments were transmitted.	79

## 8.4 The main menu

### 8.4.1 Exit

Exits menu mode.

1. Exit 2. Values 3. History 4. Settings
---

### 8.4.2 Menu 2: Measured values

This menu has no function.

### 8.4.3 Menu 3: History

The MK800 can store up to 1000 messages in the history memory (ring buffer). If more than 1000 messages are recorded by the MK800, message 1001 will overwrite the entry 1.

The "History" menu provides information about messages, acknowledgements and their time stamps. It also indicates whether an alarm is still pending or when it was acknowledged or muted with the "☒" button. The complete content of the history memory with additional texts and address of the device sending the message can be displayed on a PC and printed out using the TMK-History software version V3 or higher. All interfaces of MK800 can be used for connection.

1. Use the arrow buttons to select the entry you require.

The latest entry appears first on the display. Older messages can be selected using the arrow buttons.

Entry:	↕	0003/0003
From:		04.12.11 16:00
Ack.:		04.12.11 16:00
To:		04.12.11 16:03

2. Press the "↵" button to call up the message text of the selected entry. The path the message took to reach MK800 appears in the last line. In this case an insulation fault was received via the internal BMS bus from address 003, channel 01.

The table on the following page contains information about other possible displays.

System:		01
Insulation fault		
Meas. value:		↑
Addr/Ch:		01/003/01

3. If analogue values are displayed, as shown in the example above, the maximum and minimum values can be displayed by pressing the "▲" button.
4. Press the "↵" to return to entry selection.

Repeat these operating steps for all messages you need. Then press "ESC" button to exit the menu.

Possible displays in the last line of the history memory message text display:

Text	Meaning
Address: ee/iii/kk	Address of the device triggering the message (ee = external BMS bus address, iii = internal BMS bus address, kk= channel no. of message).
Digital Inp No.: kk	Digital input number (kk) of the digital input that has triggered the message on the device.
TESTex	Note that the latest history entry was made due to a test initiated at this MK.
TESTin	Note that the latest history entry was made due to a test initiated on the device assigned to it (insulation monitoring device, LIM, GFCI).

#### 8.4.4 Menu 4: Settings

The following menu items are available for configuring the MK800:

Menu item	Function	Page
1. Exit	Exit "Settings" menu; go up one menu level	
2. Alarm addresses	Setting bus addresses for devices so that the alarm messages of these devices can be displayed on this MK800.	64
3. Test addresses	Setting bus addresses for devices which are required to carry out a test when the "TEST" button is pressed.	65
4. Measured value addresses	No function	66
5. Digital inputs	MK800-11 only: Setting of the operating behaviour for digital inputs.	67
6. Buzzer (and LED)	Setting of the frequency and repetition rate of buzzer signal.	69
7. Common reset	Determine if the MK800 should respond to a common acknowledgement initiated by the reset button of another device.	69
8. Clock	Setting of the date and time of the real-time clock on this MK800. At the same time this setting is sent via BMS bus and all other devices are synchronised. The device with address 1 (MK800 or alarm indicator and operator panel) synchronises all other devices every hour.	70
9. Language	Selection of operating language for the MK800 (German or English).	71
10. Interface	Setting of the device address and baud rate for this MK800.	72
11. Relay	Mode of operation and function of the common alarm relay (alarm relay) on the MK800-11	73
12. Password	Change password, activate/deactivate password.	74
13. Service menu	These settings can only be made by authorised Bender Service personnel. Retrieve information about the device status, enter settings for special operating conditions and execute a firmware update.	74

### 8.4.4.1 Exit

Exit menu mode.

```

1.Exit
2.Alarm addresses
3.Test addresses
4.Value addresses
    
```

### 8.4.4.2 Settings menu 2: Alarm addresses

Setting of the bus addresses of the devices the alarm messages of which are to be displayed at this MK800. The text of individual messages can be modified using the TMK-SET software.

Select the addresses of devices whose messages are to be displayed. Set addresses are monitored for presence on the BMS bus; if a device cannot be found on the bus, a corresponding message will appear.

If several systems or areas (e.g. several operating theatres) are connected to the MK800, then numbers 1...4 can be assigned to these systems.

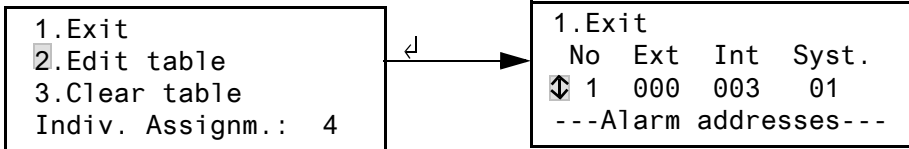

- |                 |   |
|-----------------|---|
| 1. Exit         | Back to the main menu.  |
| 2. Edit table   | Use the arrow buttons to select the line "No" and confirm with the "↵" button.<br>Use the arrow buttons to set the external BMS bus address "Ext" and confirm with the "↵" button.<br>Use the arrow buttons to set the internal BMS bus address "Int" and confirm with the "↵" button.<br>Use the arrow buttons to select the external system number "Syst" and confirm with the "↵" button.<br>MK800 always adds a new line at the end of the table which can be changed (e.g. 4 000 000 00). In this way, other alarm addresses can be activated. |
| 3. Clear table  | Deactivate all addresses ("off"). "Clear table" is only possible when no test addresses are activated.  |
| Line 4 in table | Number of programmed individual messages.   |



### Possible settings for the system number "Syst":

Syst	Meaning
00	No text appears in line 1 of the alarm message.
01...04	Texts of "System 01" to "System 04" are displayed.
T	Programmed text is displayed.
Off	Deletes the current line of the table

#### 8.4.4.3 Settings menu 3: Test addresses

Set the bus addresses for insulation monitoring devices (z. B. 107TD47, IRDH...), transfer switching devices with monitoring functions (ATICS®), LIM (Line Isolation Monitors) and GFCI (Ground Fault Circuit interrupters), which are required to carry out a test when the "TEST" button is pressed. The setting can only be made for devices which have also been activated in the "Alarm addresses" menu and/or programmed for individual alarm texts. Individual alarm texts are a minimum requirement for

- Channel 1...3 (setting "107TD47")
- Channel 1, 2 (setting "IRDHxxx")
- Channel 1 (setting "GFCI")
- Channel 1, 2, 3, 6, 7, 9 (setting "LIM")

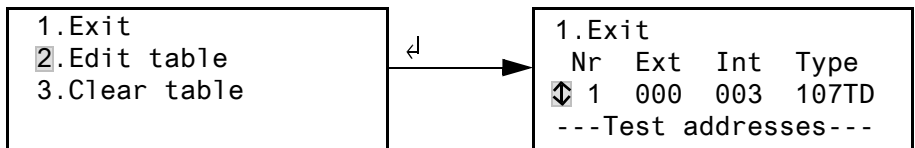

1. Exit

2. Edit table

Back to the main menu.

Use the arrow buttons to select the line "No" and confirm with the "↵" button.

Use the arrow buttons to set the external BMS bus address "Ext" and confirm with the "↵" button.

Use the arrow buttons to set the internal BMS bus address "Int" and confirm with the "↵" button.

Use the arrow buttons to select insulation monitoring device "Type" and confirm with the "↵" button.

MK800 always adds a new line at the end of the table which can be changed (e.g. 4 000 000 off). This way, other test addresses can be activated.

### 3. Clear table

Deactivate all addresses ("off").

Possible settings for "Type":

Syst	Meaning
107TD	Insulation monitoring device, e. g. 107TD47
IRDHx	Industrial insulation monitoring device, e. g. IRDH...
GFCI	Ground Fault Circuit Interrupter
LIM	Line Isolation Monitor
Off	Deletes the current line of the table

#### 8.4.4.4 Settings menu 4: Value addresses

Currently has no function.

#### 8.4.4.5 Settings menu 5: Digital inputs

Setting the operating behaviour for the digital inputs IN1...IN16 (for MK800-11 only). The following setting can be made individually for each input: "24V" (high) or "0V" (low). When the input is set to "24V" an alarm message will be sent when the voltage at the input is 10...30 V. When the input is set to "0V" an alarm message will be sent when the voltage is 0...2 V. It is for this reason that you should always set unused digital inputs to "off".

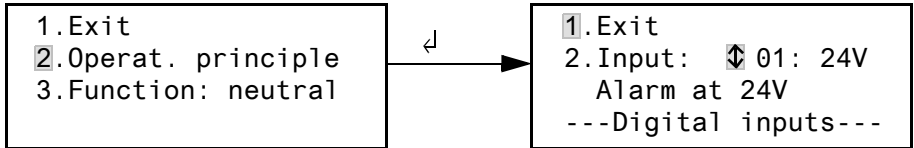

- |                   |  |
|-------------------|--|
| 1. Exit           | Back to the main menu.   |
| 2. Operation mode | Select the digital input using the arrow buttons and confirm with the "↵" button.<br>Use the arrow buttons to select "0 V", "24 V" or "Off". Press the "↵" button to accept the entry.<br>Repeat the procedure to set more digital inputs. |
| 3. Function       | Set the message text category to "neutral" or "medical", see chapter "Alarm texts for digital inputs" on page 67.  |

#### Alarm texts for digital inputs

A neutral or specific alarm message can be assigned to all digital inputs. A neutral alarm message indicates the alarm, the channel and the address of the device triggering the alarm. In comparison, the specific alarm message (medical) signals a non-modifiable pre-programmed alarm e. g. "Alarm: oxygen". Assign the inputs according to the table "Neutral and specific alarm messages" on page 68.

The TMK-SET PC software can be used to assign other messages to individual or all digital inputs.

The alarm messages in the following table are sent to other MK... or alarm indicator and operator panels via BMS bus and displayed there in plain text format.

If freely programmable alarm messages need to be displayed on a different MK800 or on an alarm indicator and operator panel, the alarm messages programmed for the display device must be identical.

## Specific alarm messages

These messages contain details regarding medical gases and BSV systems.



*Alarm messages for medical gases are signalled by the red "ALARM" LED and the buzzer sound. The buzzer can be set to mute (acknowledged). The buzzer sounds again every 15 minutes. Individual settings can only be made using the TMK-SET software.*

## Neutral and specific alarm messages

Inputs	Neutral alarm messages "Function: neutral"	Specific alarm messages "Function: medical"
IN1	Alarm: address/channel XXX/01	Alarm: oxygen
IN2	Alarm: address/channel XXX/02	Alarm: vacuum
IN3	Alarm: address/channel XXX/03	Alarm: nitrous oxide
IN4	Alarm: address/channel XXX/04	Alarm: compressed air 5 bar
IN5	Alarm: address/channel XXX/05	Alarm: compressed air 8 bar
IN6	Alarm: address/channel XXX/06	Alarm: nitrogen
IN7	Alarm: address/channel XXX/07	Alarm: CO2
IN8	Alarm: address/channel XXX/08	Alarm: BSV battery operation
IN9	Alarm: address/channel XXX/09	Alarm: BSV overload
IN10	Alarm: address/channel XXX/10	Alarm: BSV converter failure
IN11	Alarm: address/channel XXX/11	Alarm: BSV fault
IN12	Alarm: address/channel XXX/12	Alarm: BSV test run
IN13	Alarm: address/channel XXX/13	Alarm: BSV mains operation
IN14	Alarm: address/channel XXX/14	Alarm: Failure air conditioning
IN15	Alarm: address/channel XXX/15	Alarm: OP light battery operation
IN16	Alarm: address/channel XXX/16	Alarm: Sat OP light battery operation

### 8.4.4.6 Settings menu 6: Buzzer (and LED)

The buzzer will sound in the event of an alarm. Setting of the audio frequency and repetition rate of the two consecutive buzzer sounds.

1. Exit	
2. Warning:	6
3. Alarm:	8

- 1. Exit                                      Back to the main menu.
- 2. Warning
- 3. Alarm                                      A variety of signals can be preset for "Warning" and "Alarm". An individual buzzer sound can be selected via TMK-SET.

During the setting procedure the selected buzzer signal sounds and the LED lights up or flashes.

### 8.4.4.7 Settings menu 7: Common reset

Setting indicating whether this MK800 should respond (On) or not (Off) to the acknowledgement of the buzzer (buzzer mute) initiated by pressing buzzer mute button "☒"

on another MK... or TM... operator panel. When common acknowledgement is activated, a buzzer of an MK800 can also be acknowledged (muted) by an MK... or a TM... in another room.

The alarm message itself will remain visible on the display until its cause has been rectified.

1. Exit	
2. C.Reset Int.:	On
3. C.Reset Ext.:	On

- 1. Exit                                      Back to the main menu.
- 2. C.Reset Int:                              Setting for the internal BMS bus:  
 "On"            buzzer can be acknowledged externally  
 "Off"            buzzer cannot be acknowledged externally
- 2. C.Reset Ext.:                              Setting for the external BMS bus:  
 "On"            buzzer can be acknowledged externally  
 "Off"            buzzer cannot be acknowledged externally

#### 8.4.4.8 Settings menu 8: Clock

This menu is used to set the time, date and date format display. These settings remain stored after a supply failure for approx. 5 days.

The clock adjusts itself automatically to the Central European Summertime (CEST) and Wintertime (CET). Adjust the time again if the time no longer corresponds to the local time after automatic switchover. The automatic switchover can be deactivated (menu item "5. Summertime").

1. Exit	(CEST)
2. Time:	11:45
3. Date:	27.07.11
4. Format:	dd.mm.yy

1. Exit	Back to the main menu
2. Time	Set the time (hours and minutes)
3. Date	Set date (according to the format indicated in line 4)
4. Format	Select German (tt. mm. jj) or American (mm/ tt/jj)
5. Daylight sav.	Setting for automatic switchover to Central European Summertime: auto      automatic switchover off        no switchover



*Time and date of the system can be set on any MK... or TM... panel. The settings are transferred via the BMS bus to the master device (address 1), which transfers the settings to all other MK... or TM... panels.*

### 8.4.4.9 Settings menu 9: Language

Selection of the language for menu operation and message display (alarm and operating messages) at the MK800. Changes will be effective immediately.

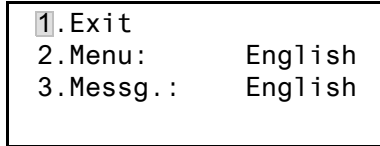

- 1. Exit                      Back to the main menu.
- 2. Menu                     Set the operating language for the menu: German or English
- 3. Mess.                    Select the language for the message display. You may select:

German	English	French
Italian	Spanish	Portuguese
Portuguese (Brazil)	Dutch	Norwegian
Swedish	Finnish	Danish
Polish	Hungarian	Czech
Slovenian	Croatian	Serbian
Turkish	Indonesian	Russian



*The language setting activates the language-specific characters. However, user-defined alarm texts remain unchanged. For this reason, you should only program and transfer individual alarm texts after language selection.*

#### 8.4.4.10 Settings menu 10: Interface

Setting of the own device address and the transfer rate (baud rate) for the connection to the BMS bus.

1.Exit	
2.Addr. ext.:	1
3.Baud ext.:	57600
4.Addr. int.:	1

- |                   |  |
|-------------------|--|
| 1.Exit            | Back to the main menu.   |
| 2. Addr. external | Setting of the external BMS bus address.<br>Addresses between 1 and 99 may be selected (factory setting: 1).<br>"Off" = external Bus is switched off.  |
| 3. Baud external  | The baud rate of the external BMS bus is selectable: 19200, 38400 or 57600 bit/s, (factory setting: 57600 bit/s). This setting can also be carried out when the external bus is switched off.  |
| 4. Addr. internal | Setting of the internal BMS bus address.<br>Addresses between 1 and 150* may be selected, (factory setting: 1).<br>This setting can only be changed when the external bus has been switched off before.<br>On the internal BMS bus the baud rate is set to a fixed value of 9600 bits/s. |

Change the corresponding device address if several MK800 are connected to one BMS bus. One MK800 must have the address 1 (master). All other MK800 are addressed in consecutive order: 2,3,4,... Gaps between addresses should be avoided. Only in this way the functionality of the system can be ensured (also refer to the "BMS bus" manual).

Data exchange will only work between devices with the same baud rate.

\* *The addresses 100...103 are intended for special tasks (e.g. programming) and therefore cannot be assigned.*



#### 8.4.4.11 Settings menu 11: Relays

Set the operation mode and function for the optional alarm relay of the alarm indicator and test combination. This menu only exists on the MK800..-11.

1. Exit 2. Operat. princ.: N/O 3. Mode: Device error
---

- |                     |   |
|---------------------|---|
| 1. Exit             | Back to the main menu.                                    |
| 2. Operation princ. | Set the operation mode:<br>N/O operation<br>N/C operation |
| 3. Mode             | Optional alarm relay switches in the event of:            |

Setting	Description
Programmable	Programming via TMK-SET -> individual alarms or operating messages
Device error	Relay switches in case of an internal fault on the MK800-11.
Common fault alarm	Relay switches in case of any warning or alarm message.
Device failure	Relay switches as soon as the MK800 recognises a device failure.
Test	Relay switches for approx. 1 second once a test has been started via the "TEST" button on the assigned devices (insulation monitoring devices, LIM, GFCI).
Buzzer	The relay switches as soon as the buzzer sounds. Also other signalling devices can be installed to indicate pending messages on the TM800.

#### 8.4.4.12 Settings menu 12: Password

Change, activate/deactivate password.

```
1.Exit
2.Password:      X X X
3.Status:        Off
```

- |             |   |
|-------------|---|
| 1. Exit     | Back to the main menu.                      |
| 2. Password | Change password. Factory setting: 807       |
| 3. Status:  | Activate or deactivate password protection. |



*Some menus are password-protected. Password protection is only effective if the password has been enabled (switched on).*

*When an attempt is made to open one of these menus, the password entry screen display appears automatically:*

```
Please enter
Password
↕ 0 0 0
```

*Once a valid password has been entered, full access will be given to all menus (except the Service menu) until menu mode is exited.*

#### 8.4.4.13 Settings menu 13: Service menu

Only Bender service personnel are authorised to make settings in the Service menu. In the Service menu, information about the device status can be called up and settings for specific operating conditions can be made.

### 8.4.5 Menu 5: Control

This menu offers various options for controlling individual devices or the overall system:

Menu item	Function	Page
1. Exit	Exit "Control" menu; go up one menu level	
2. Reset (AlarmClear)	Resetting all fault messages pending on the BMS bus	75
3. EDS Start/Stop	Manual starting/stopping of test procedure on the EDS system	76
4. Test Communication	Testing of communication via the BMS bus (MK800-11 only).	76
5. Reset mode	Determine whether a reset is to be carried out via the internal BMS bus only or also via the external BMS bus.	77

#### 8.4.5.1 Exit

Exit menu mode.

```

1.Exit
2.Reset (AlarmClear)
3.EDS start/stop
4.Test Communication

```

#### 8.4.5.2 Control menu 2: Reset (AlarmClear)

Press the "↓" button to reset all fault messages pending on the BMS bus. "Reset done!" will then appear in the last line.

```

1.Exit
2.Reset (AlarmClear)
3.EDS start/stop
Reset done!

```

This reset command is sent via the BMS bus. Note that some devices (e.g. PRC487) do not respond to this reset.

### 8.4.5.3 Control menu 3: EDS Start/Stop

Press the "↵" button to manually start and stop the measuring procedure of the EDS system. This function can only be activated by the master. The current status appears in the last line.

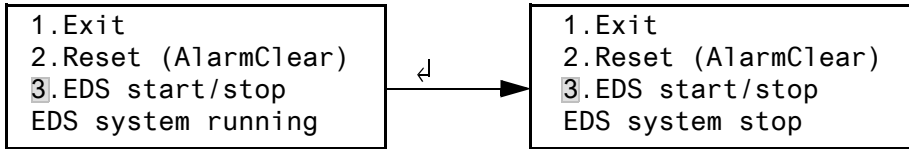

Insulation fault location running

Once started, the EDS4xx-12 and PGH47x run continuously. If the menu is exited, the standard display "EDSp" will appear in the last line in order to indicate continuous running\*.

Insulation fault location stop

Stops the EDS4xx-12 and PGH47x from continuous operation. If you exit the menu, the standard display "EDS" will appear in the last line until the current test pass finishes.

\* Other abbreviations that might appear in the last line of the display:

- EDSa                      Automatic mode: Insulation fault location has been started by e.g. ISOMETER®, ATICS® or isoMED427P on PGH47x.
- EDSs                     Single mode: A single run has been started by IN2 on PGH47x.

### 8.4.5.4 Control menu 4: Test communication

Testing the communication via the BMS bus. For this purpose, a fault message is simulated on a digital input. This fault message is sent to evaluating devices (such as MK..., TM..., SMO...) via the BMS bus. Check that these devices are responding to the fault message as requested.

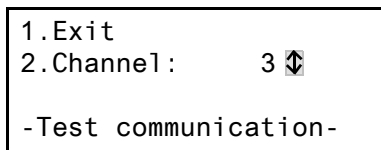

Channel 003

Setting the channel whose message is to be activated.

### 8.4.5.5 Control menu 5: Reset mode

Set whether the reset command should have an effect on the internal BMS bus only or also on the external bus: Setting possibilities

- internal only
- internal and external

### 8.4.6 Menu 6: External devices

This menu is used to set and control external devices. Functions include for example displaying information about connected devices (address, software version, device type) or continuous displaying a channel on a connected evaluating device.

Select the BMS bus to which the external device is connected.

- |   |
|---|
| <ol style="list-style-type: none"><li>1. Exit</li><li>2. Internal interface</li><li>3. External interface</li></ol> |
|---|

Internal bus                      Devices connected to the internal bus of this MK800 can be displayed and adjusted.

External bus                      Devices connected to the external bus of this MK800 can be displayed and adjusted. If other Bender devices utilising an internal bus (TM..., MK...) are addressed via the external bus, also the devices connected to this internal bus can be displayed and adjusted.

Devices which can be parameterised:  
EDS46x, EDS47x, EDS49x,  
RCMS460, RCMS470, RCMS490

All devices connected to the BMS bus are indicated. Select the address of the external device to be displayed (e.g. EDS4xx-12 or RCMS4xx-12).

```
1. Exit    (internal!)
001:  MK800-11  V4.04
002:  EDS470   V3.20
003:  107TD47  V2.52
```

Address, type and version of the connected device are displayed. If no device is detected under the address, the character "?" appears. Use the arrow buttons to select the address of the external device and confirm your selection with the "↵" button.

If the device has been recognised, the MK800 will read the current settings of the connected device. The first line of the display shows the device type.

Use the Up/Down buttons to select the appropriate function or device setting and confirm with the "↵" button. Example:

```
1. Exit    (107TD47)
2. Position mode
```

```
1. Exit    (107TD47)
2. Channel: ⬆ 1
           Re= 20 KΩ
```

in the EDS or RCMS menu there are various setting possibilities available. These are described in more detail in the operating manuals for the corresponding systems.

```
1. Exit    (EDS470)
2. General
3. Channel
4. Relay
```

### 8.4.7 Menu 7: Info

```
MK800-11 Addr. : 01/001
Software 4.02   D279
Date:         02/09/12
www.bender.de
```

Information regarding device type, firmware version and last time assignments were transmitted. Assignments are settings carried out via PC software (e.g. TMK-SET):

- Enter standard text
- Assign texts and functions to the alarm messages and digital inputs of the MK800
- Set parameters

Select:

ESC                      Exit menu mode



Show date of last assignment transmission:

```
Assignments
programmed
on:   12.07.09  07:07
```

- ▼ (press once) Show version of standard texts and version of the boot loader (internal software for updates).

```
Text version:   2.00
Bootloader     2.20
```

- ▼ (press twice)      The alarm addresses, test addresses and individual messages and the number of the devices will be displayed. Switching commands: On MK800 without function.

Alarm addresses:	0
Test addresses:	0
Indiv. Assignm.:	0
Switch.cmd.:	00/00

- ↵      Go back to the main menu

## 8.5 Overview of setting options

The MK800 supports various settings. The table below shows where the individual parameters can be set.



Parameter Name	Range	Factory setting	User setting	Adjustable via		Note
				TM600/MK600 Menu no.	TM600/MK600 Service menu item	
Buzzer settings						
Warning Alarm	(0),1..9 (0),1..9	6 8		4.6.2 4.6.3	--	Frequency setting 1, 2, buzzer interval for ALARM and WARNING, selection of predefined messages (preset)
Common reset Int.	y/n	y		4.7.2	--	Setting whether an external device should respond to an alarm acknowledgement to mute the buzzer on the int. (ext.) BMS
Ext.	y/n	y		4.7.3	--	Set the time and date / automat. summertime/wintertime on/off
Clock/date Format	dd.mm.yy / mm/dd/yy	dd.mm.yy auto		4.8.4 4.8.5	--	
Summertime	auto/off					
Language	Deutsch/English	Deutsch		4.9.2	--	Menu language setting
Message Interface	20 languages	Deutsch		4.9.3	--	
Addr. external	1..99/off	1		4.10.2	--	Switch off unused external interface
Baud external	19800..57600	57600		4.10.3	--	Ext. BMS off for single panels: faster internal communication.
Addr. internal	1..150/off	1		4.10.4	--	In case of communication problems, reduce the baud rate.
Digital output 1	Function Operating mode			4.11	--	Int. BMS off for parallel panel: faster external communication. Internal address can only be set when the ext. BMS is switched off. Setting of the function for the first digital output or relay: Test/device error/common alarm/device failure/programmable
Password prompt						Changing the password
Password Status	X X X on/off	807 on		4.12.2 4.12.3	--	Activating/deactivating the password prompt
Reset mode	int./int.+ext.	int.		5.5	--	Determine the effect of the RESET command (for devices with fault memory: EDS, RCMS, ISOMETER) via BMS
History buffer	--	--		--	2. History	Display the number of available data records.
Reset counter	--	--		--	2.2 Clear-History	Clear all data records in the history memory.
	--	--		--	3 Reset counter	Display the Power-Down, Watchdog and external reset counters
	--	--		--	3.2. Clear-Reset Count.	Reset all reset counters.
	--	--		--	4. DigitalIn/Taskbits	Indication of the digital input states and tasks
	--	--		--	5. B1800-In/BMixx-Out	a) Test of individual outputs: set the output number b) Display the buttons that are pressed
Time-Out int.	42 ms...200 ms	60 ms		--	6. Setting Timeout/SP	Timeout on int. BMS: 060 ms
Time-Out ext.	10 ms...100 ms	10 ms		--	6.2. Time-Out int. 6.3. Time-Out ext.	Timeout on ext. BMS: 010 ms at 56 k8d May only be changed for test purposes! Display the stack load in % (R: Program stack; C: Data stack)
	--	--		--	7. Timing Analysis 1 7.2 Reset values	Indication (and reset) of the max. response times with the associated address on the int. and ext. bus

Parameter Name	Range	Factory setting	User setting	Adjustable via TM800/MIK800 Menu no.	TM800/MIK800 Service menu item	TMKset Parameter menu	Note
MaxSlaveTime	500...3000 ms	3000 ms		--	8. Timing Analysis 2 8.2. MaxSlaveTime	MaxSlaveTime RS485 ext.* <sup>1)</sup>	a) Indication (and setting) of the MaxSVTime (3000 ms) When the time is exceeded, preference is given to the ext. interface b) Indication of the SlaveTimeExt (ms) c) Indication of the M.Delay.Ext (ms)
Backlight Display Time	autom / alw.on on/off	autom on		--	9. Backlight/Dis. Time 9.2 Backlight 9.3 Display Time	LCD Backlight Show date/time <sup>1)</sup>	Background lighting automatically switched on when operated or in the event of an alarm or continuously switched on. Deactivate time display in the standard display.
Max.Address Gap	1..9	3		--	10. Addr. Gap/FaultCnt 10.2 Max.Address Gap	Max.Address Gap RS485 ext.* <sup>1)</sup>	Number of passes on the ext. bus until the failure message is created.
Max.Fault Count	0..9	3		--	10.3 Max.Fault Count	Max.Fault Count Device failure alarm <sup>1)</sup>	Max. permissible number of missing answers until a failure message is generated. Affects the int. and ext. BMS. When the setting < 3 is selected, the int. BMS is set to 3. Display of the failure counter for an address on the int. BMS: „--“; no failure, „0“; failure message already activated.
Buzzer Buzzer-Type	On/Off for 1..9 h AC / DC	On AC		--	11. Buzzer On/Off/Type 11.2 Buzzer On/Off 11.3 Buzzer-Type	Buzzer On/Off <sup>1)</sup> Buzzer type <sup>1)</sup>	e.g. for the time of commissioning, the buzzer can be switched off for 1...9 h. Setting of the buzzer type : AC for int. Piezo / DC
Settings Ext. Bus	0/1	1		--	12. Settings Ext. Bus 12.2 D.....	Send state change of dig. inputs via ext. bus <sup>1)</sup>	Deactivating the forwarding of operating messages of the digital inputs 1-16 to the external bus (e.g. for flashing messages) - of all EDS/RCMS devices on the int. BMS
Settings Int. Bus ALMI Idle-Time MaxVariation	On / Off 1 s / 2 s 0.50 %	On 2 s 25 %		--	12.3 EDS/RCMS value 13. Settings Int. Bus 13.2 ALMI Idle-Time 13.3 MaxVariation	Send EDS/RCMS status via ext. bus <sup>1)</sup> ALMI Idle-Time RS485 int.* <sup>1)</sup> MaxVariation <sup>1)</sup>	Time between 2 ALMI queries on the internal BMS. If the value on the int. BMS exceeds the MaxVariation, the value will be sent again via the ext. BMS. Shall test and service messages from ATICS channel 6 be indicated?
ATICS Maintenance	On / Off	Off		--	13.4 ATICS Mainten.	Show ATICS service notes <sup>1)</sup>	Time interval at which messages are displayed alternately if different messages occur simultaneously. Display of the operating, alarm and failure messages currently pending.
Time/Message	3...8 s	3 s		--	14. Time/Message 14.2 Time	Interval for messages	Reset of the memory content: - Only reset internal parameters. - In addition reset all tables; switching commands, texts (that means, reset to delivery state)
Factory Setting	--	--		--	15. Factory Setting 15.2. Reset Parameter 15.3. Reset all		Manual firmware update (only required, if a fault occurs during program-controlled updates)
	--	--		--	16. Firmware-Update	--	

<sup>1)</sup> TMK-SET only displayed in "Expert Mode"

## 9. Technical data

### 9.1 Technical data

#### Insulation coordination according to IEC 60664-1

Rated insulation voltage .....	AC 250 V
Rated impulse withstand voltage/pollution degree .....	4 kV/3

#### Supply voltage

Supply voltage $U_s$ .....	AC/DC 24 V
Frequency range $U_s$ .....	AC 40 . . . 60 Hz/DC
Operating range $U_s$ .....	AC 18 . . . 28/DC 18 . . . 30 V
Power consumption .....	$\leq 5$ VA

#### Stored energy time in the event of power system failure

Time, date .....	> 5 days
Restart in the event of voltage failure for at least .....	1.5 s

#### Displays and LEDs

Display, characters .....	four lines, 4 x 20 characters
Standard message texts in .....	21 national languages
Alarm addresses, programmable .....	250
Text messages, programmable .....	1000
Permissible number of operating messages on the internal BMS bus .....	176
History memory (messages) .....	1000
Standard text message .....	3 x 20 characters
Additional text message (press button to access) .....	3 x 20 characters
Alarm LEDs (a set of LEDs) .....	NORMAL (green)
.....	WARNING (yellow)
.....	ALARM (red)
Menu texts .....	German/English
Buttons .....	5 (test of assigned devices, buzzer mute, additional text, scroll, menu)

#### Buzzer

Buzzer message .....	can be acknowledged, adoption of characteristics of new value
Buzzer interval .....	configurable
Buzzer frequency .....	configurable
Buzzer repetition configurable .....	configurable

**Inputs (MK800...-11 only)**

Digital inputs .....	16 (IN1 . . IN16)
Galvanic separation .....	yes
Control of digital inputs .....	via potential-free contacts/extraneous voltage
Operation mode .....	N/O, N/C operation, off, selectable for each input
Factory setting .....	Off
Voltage range (high) .....	AC/DC 10 . . 30 V
Voltage range (low) .....	AC/DC 0 . . 2 V

**Interface internal/external**

Interface/protocol .....	2 x RS-485/BMS
Baud rate internal/external (default setting) .....	9.6 kbit/s/57.6 kbit/s
Cable length .....	≤ 1200 m
Cable: twisted pair, shield connected to PE on one side .....	recommended: J-Y(St)Y min. 2 x 0.8
Terminating resistor .....	120 Ω (0.25 W) can be connected via DIP switch
factory setting .....	both on "off" position
Device address, BMS bus external/internal .....	1 . . 150/1 . . 99
Factory setting device address internal/external .....	1 (master)/1 (master)

**Programming**

Interfaces .....	RS-485
.....	or USB (V2.0/V1.1), USB cable: Type A plug on type B plug
Software .....	TMK-SET V 4.0 and higher
Factory setting password query .....	activated

**Cable length when the power supply for the MK800 is taken from AN450**

0.28 mm <sup>2</sup> .....	50 m
0.5 mm <sup>2</sup> .....	90 m
0.75 mm <sup>2</sup> .....	150 m
1.5 mm <sup>2</sup> .....	250 m
2.5 mm <sup>2</sup> .....	400 m

**Cable length when the power supply for the MK800 is taken from AN410**

0.28 mm <sup>2</sup> .....	150 m
0.5 mm <sup>2</sup> .....	300 m
0.75 mm <sup>2</sup> .....	500 m
1.5 mm <sup>2</sup> .....	1000 m
2.5 mm <sup>2</sup> .....	1600 m

**Colours**

Front foil .....	RAL 7035 (light grey) / RAL 7040 (basalt grey)
Marking .....	RAL 5005 (signal blue)
Front plate .....	RAL 7035 (light grey)

**Switching elements (MK800-11 only)**

Number .....	1 changeover contact		
Function .....	programmable		
Operation mode .....	N/C or N/O operation (programmable)		
Electrical service life under rated operating conditions .....	10,000 switching operations		
Contact data acc. to IEC 60947-5-1:			
Utilisation category .....	AC-13	AC-14	DC-12
Rated operational voltage .....	24 V	24 V	24 V
Rated operational current .....	5 A	3 A	1 A
Minimum contact rating .....	1 mA at AC/DC > 10 V		

**Environment/EMC**

EMC immunity .....	acc. to EN 61000-6-2
EMC emission .....	acc. to EN 61000-6-3
Ambient temperatures:	
Operating temperature .....	-5 ... +55 °C
Transport .....	-25 ... +70 °C
Long-term storage .....	-25 ... +55 °C
Classification of climatic conditions acc. to IEC 60721:	
Stationary use (IEC 60721-3-3) .....	3K5 (no condensation, no formation of ice)
Transport (IEC 60721-3-2) .....	2K3
Long-term storage (IEC 60721-3-1) .....	1K4
Classification of mechanical conditions acc. to IEC 60721:	
Stationary use (IEC 60721-3-3) .....	3M4
Transport (IEC 60721-3-2) .....	2M2
Long-term storage (IEC 60721-3-1) .....	1M3

Option "W" data different from the standard version

Classification of climatic conditions acc. to IEC 60721:	
Stationary use (IEC 60721-3-3) .....	3K5 (condensation and formation of ice is possible)
Classification of mechanical conditions acc. to IEC 60721:	
Stationary use (IEC 60721-3-3) .....	3M7

**Connection**

Connection .....	pluggable screw terminals
Connection properties (supply voltage, BMS bus):	
Rigid/flexible/conductor sizes .....	0.2 . . . 2.5/0.2 . . . 2.5 mm <sup>2</sup> /AWG 24-12
Flexible with ferrules, without/with plastic sleeve .....	0.25 . . . 2.5/0.25 . . . 2.5 mm <sup>2</sup>
Connection properties (inputs):	
Rigid/flexible/conductor sizes .....	0.08 . . . 1.5/0.08 . . . 1.5 mm <sup>2</sup> / AWG 28-16
Flexible with ferrules, without/with plastic sleeve .....	0.25 . . . 1.5/0.25 . . . 0.5 mm <sup>2</sup>
Stripping length .....	7 mm
Tightening torque .....	0.5 . . . 0.6 Nm (4.5 . . . 5.3 lb-in)

**Other**

Operation mode .....	continuous operation
Mounting .....	display-oriented
Degree of protection, built-in components (DIN EN 60529) .....	IP50
Degree of protection, terminals (DIN EN 60529) .....	IP20
Flammability class .....	UL94 V-0
Weight:	
Flush-mounting/cavity wall (MK800) .....	≤ 950 g
Surface-mounting (MK800A) .....	≤ 880 g
Surface-mounting (MK800AF) .....	≤ 1150 g

### 9.1.1 Standards, approvals and certifications

The MK800 alarm indicator and test combination meets the requirements of the standards DIN VDE 0100-710 (VDE 0100-710) and IEC 60364-7-710.



## 9.2 Ordering information

Type	Description	Art. No.
MK800-11	Alarm indicator and test combination acc. to DIN VDE 0100-710, with BMS bus and USB interface, 16 digital inputs, one relay output, alarm texts programmable via interfaces and personal computer, standard text display, Version: Flush-mounting enclosure; Menu languages German/English.	B 9510 0100
MK800-12	Alarm indicator and test combination acc. to DIN VDE 0100-710, with BMS bus and USB interface, alarm texts programmable via interfaces and personal computer, standard text display, version: Flush-mounting enclosure; Menu languages: German/English	B 9510 0101
MK800A-11	As MK800-11, but with surface-mounting enclosure.	B 9510 0102
MK800A-12	As MK800-12, but with surface-mounting enclosure.	B 9510 0103
MK800AF-11	As MK800-11, but with surface-mounting enclosure with front door.	B 9510 0104
MK800AF-12	As MK800-12, but with surface-mounting enclosure with front door.	B 9510 0105
MK800E-11	As MK800-11, but as built-in type without enclosure.	B 9510 0106
MK800E-12	As MK800-12, but as built-in type without enclosure.	B 9510 0107

Type	Description	Art. No.
UP800	Flush-mounting enclosure for MK800	B 9510 0110
BR800-1	Bezel frame silver for MK800	B 9510 0111
BR800-2	Bezel frame white for MK800	B 9510 0112
Parameteri- sation software	<ul style="list-style-type: none"><li>- TMK-SET V 4.x parameterisation software for MK2430, MK800, TM800,</li><li>- TMK-History V 3.x for MK2430, MK800, TM800, TM1000 and PRC1470</li><li>- USB driver software for MK2430, MK800 and TM800</li><li>- MEDISET V1.x parameterisation software for TM1000 and PRC1470</li></ul>	by Internet download



# INDEX

## A

- Accident prevention 11
- Acknowledgement 69
- Acknowledgements 61
- Additional text 52
- Address settings 32
- Alarm
  - Repetition 15
- Alarm addresses 16, 64
- Alarm indicator and operator panel 18
- Alarm message 14, 16
  - neutral 67
  - specific 67
- Alarm relay 47, 73
- Assignments 79
- Automatic mode 76

## B

- Baud rate 72
- Beep code 47
- Bender service personnel 74
- BMS bus
  - internal 18
- BMS bus address 72
- Buzzer
  - Audio frequency 69
  - Reminder 68

## C

- Cable length 27
- Cable lengths 27
- Cavity wall mounting 20
- Changeover periods 43
- Characteristics 15
- Clear text display 9

- Commissioning 37
- Commissioning pattern 37
- Common acknowledgement 69
- Connection 27
- Control 75
- Control panel mounting
  - with enclosure 22

## D

- Date 70
- Date format 70
- Device address 72
- Diagram 59
- Digital inputs 67
- digital inputs 29
- Dimensions 11
- Display 16
- Display and operating units 14
- Display functions 9
- Displaying information 77
- Disturbances 11

## E

- electrostatic electricity 26
- ENTER button 52
- Equipment failures 14
- Error list 49
- Errors 47
- Evaluating devices 77
- Example 14
- External devices 77

## F

- Fault
  - condition 53

Firmware version 57, 79  
Flush-mounting enclosure 20  
Front panel 21  
Functional test 43  
Functionality 14

## G

Gases  
- medical 9, 68  
Gateways 14

## H

History memory 17, 18, 61  
- read out 17

## I

Indication  
- audible 9  
- visual 9  
Individual alarm texts 65  
Inputs  
- digital 14, 17, 27, 67  
Installation documentation 37  
Intended use 9  
Interface 17, 72  
interface 17

## L

Language 71  
LEDs 16  
Liability 7

## M

Main menu 58  
Master 18  
Master clock 18  
Measurement addresses 66  
medical gases 68

MEDICS® 13  
Menu mode 58  
Message text display 62  
Message texts 15, 17  
MK800-11 17  
MK800-12 17  
Monitoring modules 14

## N

National languages 15, 16  
Navigation 59  
Normal  
- operating conditions 53

## O

Office buildings 10  
Operation 51  
Ordering information 87

## P

Panel mounting  
- without enclosure 21  
Parallel indication 14, 17  
Parameter setting 15  
Parameterisation 39  
Parameters 80  
Password 58, 74  
Periodic verification 43  
Personnel 10  
Plain text 14  
Planer 7  
potential free contacts 17  
potential-free contacts 29  
Protocol converters 14

## Q

Quick reference guide 51

**R**

Relay mode 73  
Relay output 27, 29, 30  
Relay outputs 14  
Replacement parts 11  
Reset 75  
Reset mode 77  
Risks 11

**S**

Scroll 52  
Selective operation 11  
Service menu 74  
Setting possibilities 80  
Setting values 43  
Settings 18, 39, 40, 41, 63  
Shape stability 20  
Single mode 76  
Slave 18  
Software 16, 18  
Standard display 57  
Standards 87  
Starting procedure 57  
Starting the EDS system 76  
Status information 16  
Status line 54, 55  
Summertime 70  
Surface-mounting enclosure 24, 25  
Switching on 38, 39  
System components 7  
System number 65

**T**

Terminating resistor 29, 31  
Terminating resistor  
    27  
Termination of the BMS bus 30  
TEST 52  
Test 55

- Error code 55  
- Error code note 56  
Test addresses 65  
Test communication 76  
Test intervals 10  
Test procedure 76  
Tests 37  
Text display 16  
Text messages 17  
Time 70  
    - entire system 70  
    - synchronise 18  
TMK HISTORY 18, 61  
TMK-SET 18, 39, 41, 64, 67, 68  
Transfer rate 72

**U**

USB cable 18  
USB interface 18  
Use  
    - intended 10

**V**

Value addresses 66

**W**

Warranty 11  
Wiring diagram 26











**Bender GmbH & Co. KG**

P.O. Box 1161 • 35301 Gruenberg • Germany  
Londorfer Straße 65 • 35305 Gruenberg • Germany  
Tel.: +49 6401 807-0 • Fax: +49 6401 807-259  
E-mail: [info@bender.de](mailto:info@bender.de) • [www.bender.de](http://www.bender.de)

Photos: Bender archives.



**BENDER Group**