

# Operating Manual

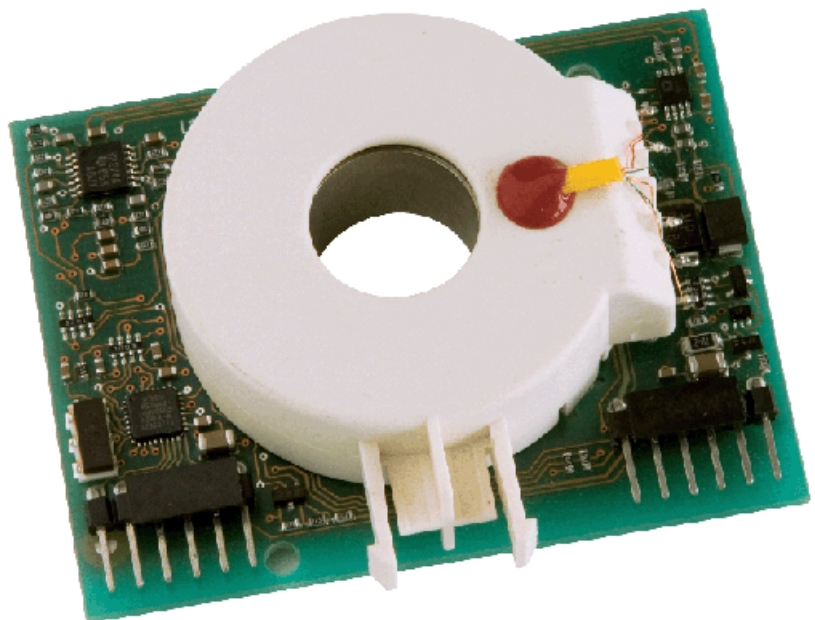

## **RCMA126P1-S**

**AC/DC sensitive  
residual current monitoring module  
for installation into photovoltaic converters  
Software version 9**

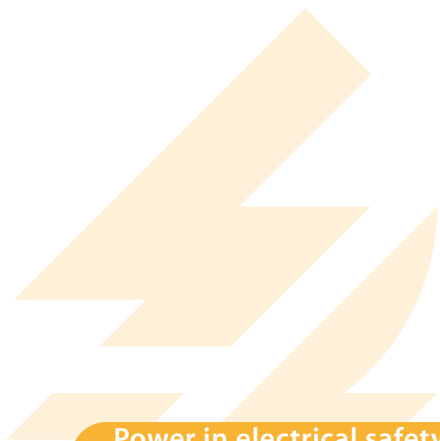



Dipl.-Ing. W. Bender GmbH & Co. KG  
Londorfer Str. 65 • 35305 Grünberg • Germany  
Postfach 1161 • 35301 Grünberg • Germany

Tel.: +49 6401 807-0  
Fax: +49 6401 807-259

E-mail: [info@bender-de.com](mailto:info@bender-de.com)  
Web: <http://www.bender-de.com>

**BENDER Group**

© Dipl.-Ing. W. Bender GmbH & Co. KG

All rights reserved.  
Reprinting only with permission  
of the publisher.  
Subject to change!

# Table of Contents

<b>1. Effective use of this manual .....</b>	<b>5</b>
1.1 Notes for the user .....	5
<b>2. Safety information .....</b>	<b>7</b>
2.1 General safety information .....	7
2.2 Work activities on electrical installations .....	7
<b>3. Function .....</b>	<b>9</b>
3.1 Product description .....	9
3.2 Function .....	9
3.3 Measurement technique: .....	9
<b>4. Installation, connection .....</b>	<b>11</b>
4.1 Connection assignment .....	11
<b>5. Operation and setting .....</b>	<b>13</b>
5.1 PWM measured value output X1 .....	13
5.2 Interface protocol .....	13
5.2.1 SPI timing .....	14
5.2.1.1 Timing for the receipt of one byte from the master .....	14
5.2.1.2 Timing for the communication cycle from the Master .....	14
5.2.2 Messages .....	15
5.2.2.1 RESET .....	15
5.2.2.2 Selecting the measuring range .....	15
5.2.2.3 Hardware version query .....	16
5.2.2.4 Software version query .....	16
5.2.2.5 Status query .....	16
5.2.2.6 Function control .....	17
5.2.2.7 Reading slave data .....	17
5.3 Other hardware features .....	17
5.4 Other software features .....	18
5.5 Measuring range and measuring times .....	18
5.5.1 Measuring range 30 mA, 100 mA .....	18

5.5.2 Measuring times .....	18
<b>6. Technical data .....</b>	<b>19</b>
6.1 Data in tabular form .....	19
6.2 Ordering information .....	20
6.3 Dimension diagrams .....	21

# 1. Effective use of this manual

## 1.1 Notes for the user

**This manual is intended for electrically skilled persons in electrical engineering and electronics!**

In order to make it easier for you to find specific text passages or references in this manual and for reasons of comprehensibility, important information is emphasised by symbols. The meaning of these symbols is explained below:



---

*Information calling attention to hazards are marked with this warning symbol.*

---



---

*Information intended to assist the user to make optimum use of the product are marked with the Info symbol.*

---



## 2. Safety information

### 2.1 General safety information

In addition to this data sheet, the documentation of the device includes a sheet entitled "Important safety instructions for Bender products".

### 2.2 Work activities on electrical installations

- All work activities necessary for installation, commissioning or work activities during operation of electrical devices or systems are to be carried out by adequately skilled personnel.
- Observe the relevant regulations applying to work on electrical installations, in particular DIN EN 50110 or its subsequent regulations.

Unprofessional work activities on electrical installations may result in a threat of danger to life and limb!

- If the equipment is used outside the Federal Republic of Germany, the respective national standards and regulations are to be observed. The European standard EN 50110 is recommended to be used as a directive.





## 3. Function

### 3.1 Product description

The AC/DC sensitive residual current monitoring module RCMA126P1-S is suitable for fault current monitoring in transformerless photovoltaic inverters where direct and/or alternating fault currents are likely to occur the value of which is constantly greater than zero.

### 3.2 Function

Residual current monitoring is carried out using an internal measuring current transformer. The r.m.s. value is calculated by summing up the DC components included in the residual current and the AC components that are below the cut-off frequency. A PWM signal in proportion to the residual current is available at the module output (X1). If values are outside the permissible measuring range, the signal will be available for 1 s after disconnection. The PWM frequency is 8 kHz.

The measuring range 0...30/100 mA equates to 3...97 % PWM.

Measured values < 3 % and > 97 % signal that the residual current monitoring module is inactive respectively defective. The residual current monitoring module is operated as a slave on a SPI interface. The measuring range can be changed via the interface. In addition, the software version and the statuses can be queried and a functional test can be carried out.

The monitoring module can be tested via the test winding at the module output (X11) using an actual fault current (X11). For this purpose, a voltage of +3.3 V is applied at the connection k of the test winding. Connection l of the test winding is connected to the module output X11.

### 3.3 Measurement technique:

The residual current is measured using the magnetic saturation measurement principle. This AC/DC sensitive method allows residual DC currents and residual AC currents to be detected. The frequency range is 0...500 Hz.



## 4. Installation, connection

### 4.1 Connection assignment

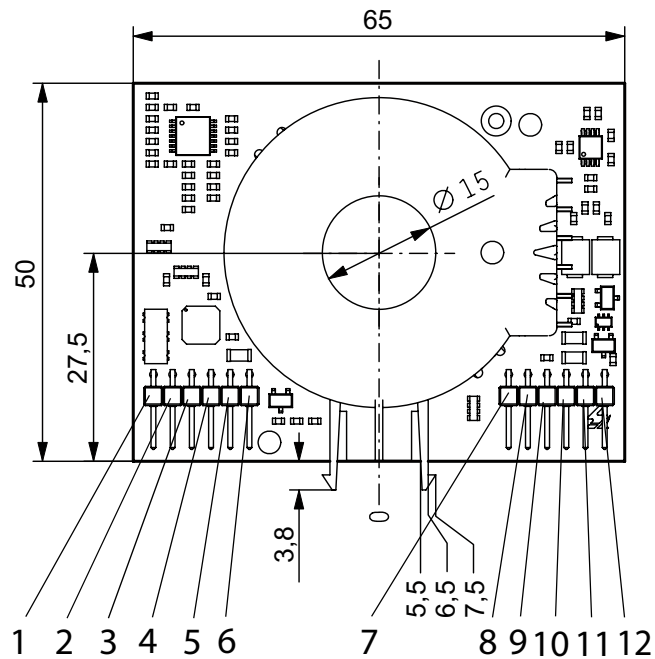

No.	Plug designation	Description
1	X1	PWM (measured value output)
2	X2	CS (ChipSelect interface)
3	X3	SCK (CLOCK interface)
4	X4	MISO (data output interface)
5	X5	MOSI (data input interface)
6	X6	U4 (voltage supply +3.3 V)
7	X7	U2 (voltage supply +5 V)
8	X8	AGND (ground)
9	X9	U3 (voltage supply -5 V)
10	X10	(voltage supply +15 V)
11	X11	(test winding)
12	X12	(ground)



## 5. Operation and setting

### 5.1 PWM measured value output X1

The measured residual current is available at the measurement output X1 as a PWM signal in proportion to the residual current. Values outside the permissible measuring range are available for approximately 1s after disconnection. The PWM frequency is 8 kHz.

Sensitivity of the device:

- Measuring range 30 mA:  $M = 30 \text{ mA} / 97 \% = 0.3093 \text{ mA}/\%$  pulse width  
0...30 mA equates to 0...97 %, where measured values < 3 % are output with 3 % PWM
- Measuring range 100 mA:  $M = 100 \text{ mA} / 97 \% = 1.0309 \text{ mA}/\%$  pulse width  
0...100 mA equates to 0...97 %, where measured values < 3 % are output with 3 % PWM.

Measured values smaller than 3 % are output with a 3 % pulse width.

A pulse width of > 97 % resp. < 3 % signals an inactive residual current monitoring module, the start-up phase of the software or an error message.

### 5.2 Interface protocol

The residual current monitoring module is operated as a slave on an SPI interface. The slave responds to a command by writing the associated answer to the send buffer. In response to the command "Get slave data", the master then reads data from the slave. The answer read from the slave is only valid for the master when the command "Get slave data" has been sent before. A command consists of 1 byte.

The SPI interface is operated with the following parameters:

- Clock = 200 kHz, clock inactive LOW
- Data sample on clock's rising edge, data setup on clock's falling edge
- MSB first
- SlaveSelect (CS) LOW during transmission

A communication cycle consists of the following transmission sequence:

- Master is sending a command byte while SlaveSelect is LOW
- Master is waiting  $t_{\text{pause1}}$  while SlaveSelect is HIGH
- Master is sending the command "Get answer" while SlaveSelect is LOW

The next cycle will be repeated by the master after a waiting period of  $t_{\text{pause2}}$ , at the earliest.

## 5.2.1 SPI timing

### 5.2.1.1 Timing for the receipt of one byte from the master

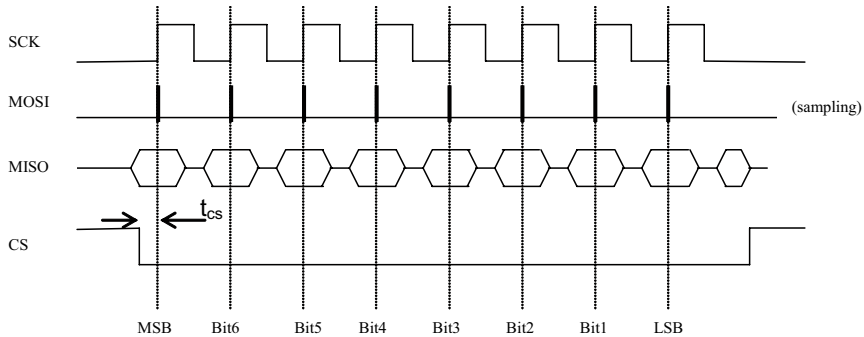

$$t_{cs} > 20ns$$

SPI signals:

- SCK: Clock, generated by the master
- MOSI: Data is sampled by slave
- MISO: Data output from slave
- CS: Slave-Select signal from master

### 5.2.1.2 Timing for the communication cycle from the Master

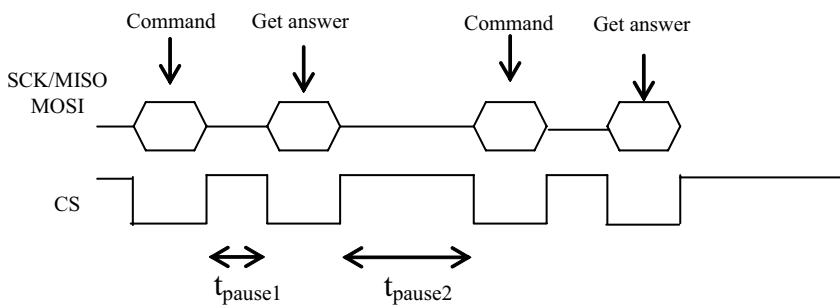

$$t_{\text{pause1}} \geq 1.5 \text{ ms}$$

$$t_{\text{pause2}} \geq 200 \text{ ms}$$

## 5.2.2 Messages

### 5.2.2.1 RESET

Converter	Command	Send 0x80h
RCMA126	Answer	0x80h
	Action	Software reset and restart. Initialisation and self calibration

While resetting the residual current module, ensure that no residual current is flowing, since the RCMA126P1-S carries out a self calibration during software start-up.

The reset procedure takes up to 2 seconds after the slave has checked that the supply voltage +15V is not outside the tolerance. The device status can be queried during this period.

The RCMA status is "inactive" for the duration of the reset procedure. During this time the measuring range cannot be changed. The command also deletes the counter of the function control. Therefore this command is not allowed during the reset procedure. The answer will then always be 0x80.

Recommended command sequence under consideration of the timing:

- Send reset command
- Send status command until the message "RCMA active" is sent.

The response to this command will be written into "Answer" register. In this case "Answer" from RCMA126P1-S means that the received value will be written into the SPI send register. The master can get this answer byte by sending a dummy command (0x00h) to which the RCMA126P1-S does not initiate an action. The value previously written into the send register will then be clocked into the master.

### 5.2.2.2 Selecting the measuring range

Converter	Command	Send 0x88h: Measuring range 100 mA Send 0x84h: Measuring range 30 mA
RCMA126	Answer	Measuring range 100 mA: 0x88h: RCMA active 0x89h: RCMA inactive  Measuring range 30 mA: 0x84h: RCMA active 0x85h: RCMA inactive
	Action	Setting the measuring range

Measuring range 100 mA:

0...100 mA equates to 0...97 %, where measured values < 3 % are output with 3 % PWM.

Measuring range 30 mA:

0...30 mA equates to 0...97 %, where measured values < 3 % are output with 3 % PWM.

After powering up, the residual current monitoring module always starts in the 100 mA measuring range. A change of the measuring range will not be stored permanently.

### 5.2.2.3 Hardware version query

Converter	Command	Send 0x81h
RCMA126	Answer	>= 0x01h (will be incremented each time the hardware is changed)

### 5.2.2.4 Software version query

Converter	Command	Send 0x86h
RCMA126	Answer	>= 0x01h (will be incremented each time the software is changed)

### 5.2.2.5 Status query

Converter	Command	Send 0x83h
RCMA126	Answer	Coded bit by bit: Bit 0: 0 = RCMA inactive, 1 = RCMA active Bit 1: 0 = measuring range 100 mA, 1 = measuring range 30 m A Bit 2: 1 = self test active Bit 3: 1 = device calibration active Bit 4: 1 = common fault alarm Bit 5: unused Bit 6: always 1 Bit 7: always 1

The device status and measuring range can be queried. During the start and initialisation phase and in case of an error, the status is "inactive", i.e. Bit 0 = 0. In this case, the PWM duty cycle is 1 %.

Meaning of the bits:

Bit 0: 1 = RCMA126P1-S active, the output measuring signal is valid

Bit 1: specifies the currently set measuring range

Bit 2: is 1 during the initialisation phase of the software and during the cyclic self test of the RCMA126P1-S (approx. every 5 hours)

Bit 3: is 1 during an offset measurement (is carried out after powering up and a reset command)

Bit 4: general error flag that will be set if:

- during an internal self test a microcontroller error has been detected
- the measurement oscillator does not oscillate in the required range
- the deviation recognised during the offset measurement is too big

Bits 2, 3 and 4 only provide additional information about the device status. The residual current monitoring module will become active (Bit 0 = 1) as soon as a residual current measurement can be carried out. A residual current exceeding the measuring range results in a duty cycle of 97 %. In this case, the status will remain "active".

The status can be queried approx. 100 ms after powering up of the residual current monitoring module, at the earliest (Enable of the SPI interface after the self test and before calibration).



### 5.2.2.6 Function control

Converter	Command	Send 0x82h
RCMA126	Answer	>= 0x00h The value returned will be incremented each time a command is requested and will be reset to 0x00h when 0xffh is exceeded.

For function control, the residual current monitoring module returns a value which is incremented whenever a command is requested. The start value for a software restart and after a reset command is 0x00h.

### 5.2.2.7 Reading slave data

Converter	Command	Send 0x00h
RCMA126	Answer	no answer!

This command enables the master to read in the contents of the slave register. In contrast to all other commands, the send register will not be changed by the slave. Synchronisation by the master also takes place.

## 5.3 Other hardware features

The accuracy of residual current measurement depends on the supply voltage U1 (+15 V). For this reason, continuous supply voltage monitoring is required to check that the voltage is U1 = 13.5 V. If the voltage falls below the required minimum voltage, residual current measurement will be deactivated (status: RCMA inactive). Simultaneously, the measured value output will be set outside its area of validity (PWM output = 1 %).

The residual current transformer utilises a test winding with N = 20 windings. The test winding is connected to the X11 (T) connection. The end of the second winding is connected to U4 = +3.3 V on the residual current monitoring module.

## 5.4 Other software features

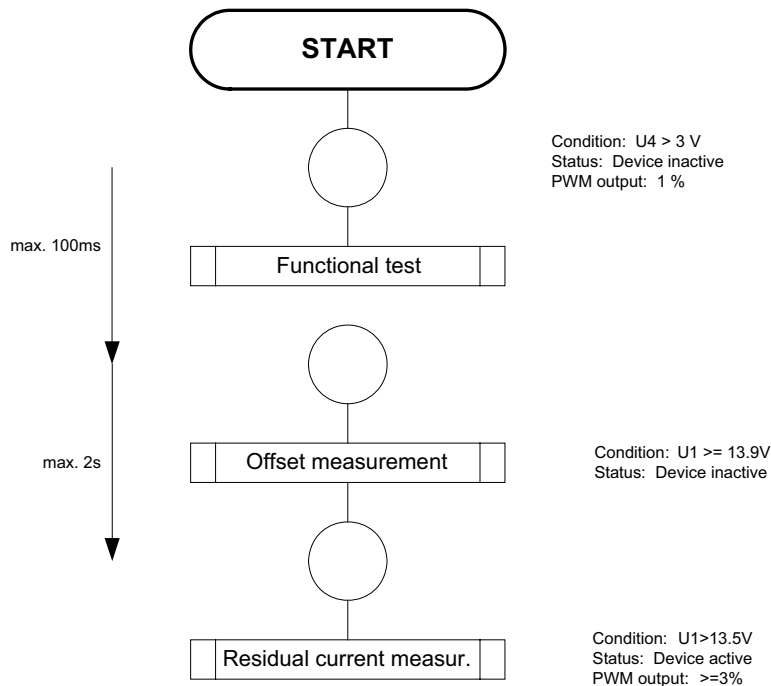

The microcontroller only becomes active if the minimum supply voltage  $U_4 > 3.0\text{ V}$  will be exceeded. Initially, the microcontroller carries out a self test of the hardware and software of the residual current monitoring module. During the start-up phase, it must be ensured that the supply voltage is  $U_1 \geq 13.9\text{ V}$  and that no residual current is flowing. Only when residual current measurement is started, the device status will be set to "active".

## 5.5 Measuring range and measuring times

### 5.5.1 Measuring range 30 mA, 100 mA

By default, the measuring range is 0...100 mA.  
The measuring range is set via the SPI interface.

### 5.5.2 Measuring times

Change in residual current	Measuring time	Minimum output value after the measuring time has elapsed
30 mA	$\leq 150\text{ ms}$	$\geq 30\text{ mA}$
60 mA	$\leq 100\text{ ms}$	$\geq 40\text{ mA}$
150 mA	$\leq 20\text{ ms}$	100 mA (limit of measuring range)

The measuring time starts when the residual current occurs and ends when the pulse width of the monitoring module is set in proportion to the residual current. The change in residual current is the amount of increase based on a static value within the measuring range. In this case, the measuring times can only be reached when the residual current rises rapidly.

## 6. Technical data

### 6.1 Data in tabular form

#### Voltage supply

U1.....	+15 V (±5 %)
U2.....	+5 V (+12 % / -5 %)
U3.....	-5 V (+12 % / -5 %)
U4.....	+3.3 V (+10 % / -5 %)
Ripple max.....	60 mV
Power consumption .....	≤ 0.5 W

#### Measuring circuit

Operating characteristics acc. to IEC 60755.....	Type B
Frequency range .....	0... 500 Hz
Measuring range .....	0... 30 / 100 mA
Relative uncertainty .....	0... -20%
Max. nominal current.....	50 A / 50... 60 Hz

#### Outputs

PWM frequency.....	8 kHz
Tolerance of the PWM frequency.....	±1 %
Sensitivity measured value output:	
Measuring range 0... 100 mA .....	100 mA / 97 %
Measuring range 0... 30 mA .....	30 mA / 97 %
Resolution of setting	
100 mA range.....	0.76 %
30 mA range.....	0.76 %
Interface.....	SPI
Clock frequency.....	200 kHz

#### Specified time

Changes in residual current $I_{\Delta} = 30$ mA (output X1).....	≤ 150 ms
..... minimum output value after reaching the measuring time:	≥ 30 mA
Changes in residual current $I_{\Delta} = 60$ mA (output X1).....	≤ 100 ms
..... minimum output value after reaching the measuring time:	≥ 40 mA
Changes in residual current $I_{\Delta} = 150$ mA (output X1).....	≤ 20 ms
..... minimum output value after reaching the measuring time:	100 mA (limit of measuring range)

#### Classification of mechanical conditions

Operating conditions in acc. with EN 60721-3-3.....	Class 3M6
Shock resistance .....	25 g / 6 ms
Vibration resistance.....	2... 9 Hz / 7 mm, 9... 200 Hz / 2 g

#### Environmental conditions

Climatic class acc. to IEC 60721-3-4 .....	4K4H
Ambient temperature, during operation.....	- 25 °C... + 80 °C
Ambient temperature, during transport.....	- 40 °C... + 80 °C
Relative humidity .....	10... 90 %, 100 % max. 48 hours
Air pressure.....	70... 106 kPa
Condensation, ice formation.....	possible temporarily

**Connection**

Plug-in connectors for PCBs, single-row ..... 0.65 mm x 0.65 mm

Modular dimensions ..... 2.54 mm

**Other**

Operating mode ..... continuous operation

Position of normal use ..... any

Weight .....  $\leq 55$  g**6.2 Ordering information**

Type	Measuring range	Frequency range	Art. No.
RCMA126P1-S	0...30 / 100 mA	0...500 Hz	B 9404 2085

### 6.3 Dimension diagrams

Dimensions are given in mm

Bender p.c.b. RCMA126P1-S of 1.5 mm thickness

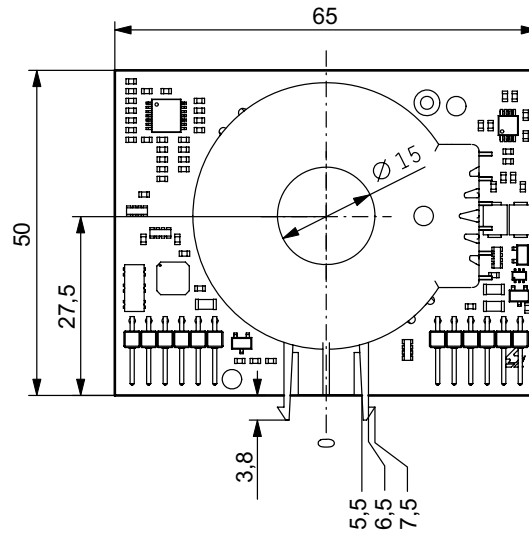

Bender p.c.b. on base plate

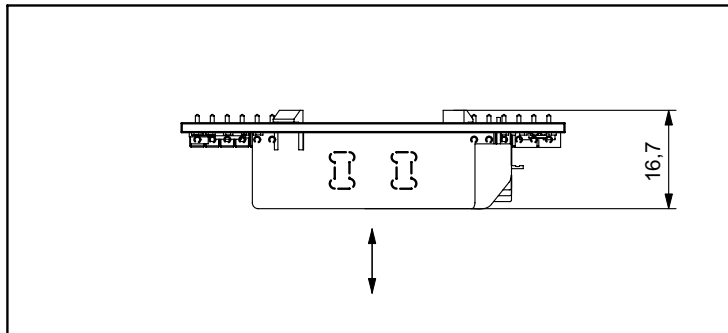

Base plate

Features: of 1.7 mm thickness, tolerance: +0.1 mm / -0 mm

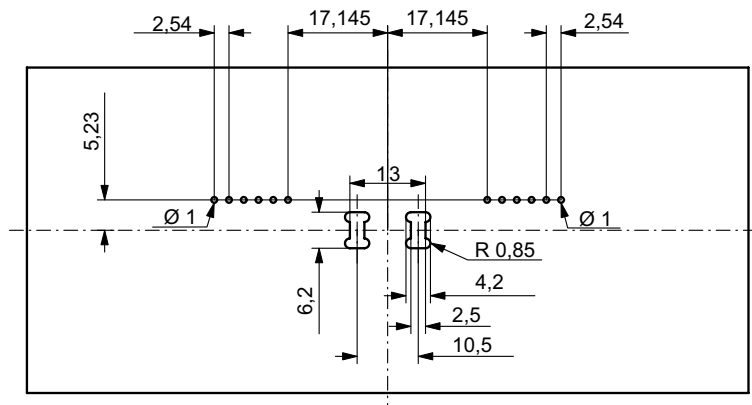





**Dipl.-Ing. W. Bender GmbH & Co. KG**

Londorfer Str. 65 • 35305 Grünberg • Germany  
Postfach 1161 • 35301 Grünberg • Germany

Tel.: +49 6401 807-0

Fax: +49 6401 807-259

E-Mail: [info@bender-de.com](mailto:info@bender-de.com)

Web: <http://www.bender-de.com>

